

# ModuTEMP® 70

## Modular Resistance and Thermocouple Temperature Sensors without/with Transmitter

- Measuring resistor 1x / 2x Pt100, thermocouple 1x / 2x “J“, “K“, “N“
- Measuring range -200 to +700 °C (Pt100), -200 to +800 °C (“J“), -200 to +1300 °C (“K“, “N“)
- Accuracy class A, B according to EN 60751, 1, 2 according to EN 60584-1
- Stem material stainless steel 1.4541, 1.4404, 2.4816, Microbell/Pyrosil.
- Extension piece (thermowell) material stainless steel 1.4541
- Protective tube material stainless steel 1.4541, 1.4845, 1.4762, Kanthal AF
- Optional headmounted transmitter with output 4 to 20 mA, HART, Profibus, Fieldbus, including version with galvanic isolation and intrinsically safe version
- Housing IP 65, IP 68
- Intrinsically safe version
  - ⊕ II 1/2G Ex ia IIC T6...Tx°C Ga/Gb,
  - ⊕ II 1D Ex ia IIIC T85°C...Tx°C Da
- Flameproof enclosure
  - ⊕ II 1/2G Ex da/db IIC T6...Tx°C Ga/Gb
- Protection by enclosure
  - ⊕ II 1/2D Ex ta/tb IIIC T90°C...Tx°C Da/Db



### Application

Industrial resistance (RTD) and thermocouple (TC) temperature sensors ModuTEMP® 70 made on the basis of interchangeable measuring inserts with mineral insulation are designed for accurate remote temperature measuring and temperature control of liquid and gaseous mediums in non-hazardous or in hazardous locations with potentially explosive atmosphere of gases or dusts (ATEX certificate).

Sensors can be supplied with connecting terminal box or with transmitter with output from 4 to 20 mA, possibly HART, Fieldbus, Profibus mounted in the sensor head.

#### J23, J32, J33, J63 - Sensors with thermowell

Sensors are intended for temperature measurement of flowing fluids, gasses and powdery mediums in pipelines, tanks, etc., at low to medium pressures and flowing velocities of a medium. Thermowell is in this case an integral part of the sensor.

Submersible part of the sensor (thermowell) or possibly adjacent part for sealing (at sensor with a flange) can be coated by special plastic paint (Halar, Hyflon, polyamide, etc.) to increase corrosion resistance. Increasing resistance of thermowell against abrasion and erosion can be provided by coating with resistant corundum or other layer.

#### J13, J16, J21P - Sensors into thermowell

The sensors into the thermowell must be assembled with appropriate cylindrical or conical thermowell. Using this sensors without thermowell is not recommended and for flameproof enclosure (code ED) and protection by enclosure (code ET) version is prohibited.

The sensors in combination with suitable thermowell are intended for temperature measurement of flowing fluids, gasses and powdery mediums in pipelines, tanks, etc., at middle to high pressures (PN 250, PN 400) and flowing velocities of mediums (90 m/s).

Measuring insert RTD is efficient up to 700 °C, measuring insert TC “J“ up to 800 °C and “K“, “N“ up to 1300 °C, although measuring range of complete sensor is given by temperature resistance of used thermowell. The massive high-proof thermowells made of special materials extend the time of the sensor reaction. The strengths of these sensors are in easy operating service without breach of pressure technology tightness.

#### J43 - Sensors without thermowell

These sensors do not have protective thermowell and the sheath of measuring insert is directly in contact with the medium. The measuring insert is inseparably connected (welded, soldered) with a sensor fitting. Sensors are intended for measurement with higher requirements on quick reaction time of temperature change. They are used for lower pressures and lower velocities of medium.

#### B00, B01 - Sensors without fitting

Sensors are intended for temperature measurement of flowing and non-flowing fluids, gasses and powdery mediums at relative low pressures and flowing velocities of medium, at higher requirements on short reaction time of temperature change.

The required immersion is adjustable by fixing shift pipe union.

The stem length of sensor is not limited. Sensors with a length over one meter are supplied as default with measuring stem coiled into a circle.

The sensor can be used also for measurement of surface temperature and temperature in hard accessible places, where is used of advantage of workable stem with minimal curve diameter 5D, where D is diameter of the sensor stem.

**B53, B63, B64, B66, B73, B74, B83, B84, B85, B86, B84Z, B842, B843, B852, B853 - Straight sensors**

Straight sensors are intended for temperature measurement of liquid, gaseous and powdery mediums in furnaces, incinerators with overpressure up to 100 kPa.

Increasing resistance against abrasion and erosion can be provided by coating with resistant corundum or other layer.

**P1E - Spatial sensors for explosive atmosphere of gasses or dusts**

Spatial sensors are intended for ambient temperature measurement in locations of their installation.

**Installation of the sensors into explosion hazard environment acc. to EN 60079-0, EN 60079-1, EN 60079-10 and EN 60079-31**



Any intervention into construction of the sensor with a ED, ET or EI version is not permitted and may cause an explosion!

**J13, J16, J21P - Sensor into thermowell in ED, ET, EI version**

Sensor into thermowell can be placed in, Zone 1, 2, 21, 22. Sensor must be mounted into the protective thermowell. Wall thickness of the thermowell must be at least 1 mm. Material of the thermowell must resist in the long term influence of medium and ambient environment. Protective thermowell can be installed in Zone 0, 1, 2, 20, 21, 22 according to EN 60079-10.

**J23, J32, J33, J63 - Sensor with thermowell in ED, ET, EI version**

Submersible part of the sensor (thermowell) can be mounted in Zone 0, 1, 2, 20, 21, 22 according to EN 60079-10. Other parts of the sensor (head, extension piece) can be placed in Zone 1, 2, 21, 22.

**B53, B63, B64, B66, B73, B74, B83, B84, B85, B86, B84Z, B842, B843, B852, B853 - Straight sensor in ED, ET, EI version**

Submersible part of the sensor (protective tube) can be placed in Zone 0, 1, 2, 20, 21, 22 according to EN 60079-10. Head of the sensor can be placed in Zone 1, 2, 21, 22.

**P1E - Spatial sensors in ED, ET, EI version**

Sensor can be mounted in Zone 1, 2, 21, 22 according to EN 60079-10. Head of the sensor can be placed in Zone 1, 2, 21, 22.

**J43 - Sensor without thermowell in EI version**

Submersible parts of the sensor (stems of measuring inserts) can be placed in, Zone 0, 1, 2, 20, 21, 22 according to EN 60079-10. Other parts of the sensor (head, extension piece) can be placed in Zone 1, 2, 21, 22.

**B00, B01 - Sensor without fitting in EI version**

Submersible part of the sensor (stem of measuring insert) can be placed in, Zone 0, 1, 2, 20, 21, 22 according to EN 60079-10. Head of the sensor can be placed in Zone 1, 2, 21, 22.

**All sensors in EI version with heads H5, H5N, H6 or H7**

These sensors with respect to other installation conditions can be fully mounted in Zone 20.

**Description**

Modular concept, variable dimension and used materials simplify ordering and application of modular temperature sensor ModuTEMP® 70.

Main part of the sensor is exchangeable measuring insert assembled with head and in some versions with protective fitting of the sensor.

Exchangeable measuring insert is fastened in sensor head by two suspended screws, providing down-force on thermowell bottom (or protective tube).

RTD - Resistance sensor is made of one or two measuring resistors, embedded in the stem of exchangeable measuring insert. Resistors are connected by inner wiring to the terminal block in the sensor head. There is used defined resistance change according to temperature change. At sensors with transmitter is resistance signal further transformed to linearized unified current signal 4 to 20 mA, optionally to HART, Profibus, Fieldbus output.

TC - Thermocouple sensor is made of one or two thermocouples, embedded in the stem of exchangeable measuring insert and connected to terminal block in the sensor head. There is used the defined change of thermoelectric voltage according to the temperature change. At sensors with transmitter is output thermocouple signal further transformed to linearized unified current signal 4 to 20 mA, optionally to HART, Profibus, Fieldbus output.

**Technical specifications**

**Resistance sensors type T1070**

**Measuring resistor:**

1xPt100, accuracy class A, B according to EN 60751, inside wiring: two-wire, four-wire  
2xPt100, accuracy class A, B according to EN 60751, inside wiring: two-wire, three-wire

**Measuring range:**

-200 to +700 °C

**Measuring current:**

recommended ≤ 1 mA  
maximal 2 mA

**Output signal:**

without transmitter resistance  
with transmitter linearized 4 to 20 mA,  
other after agreement

**Dielectric strength:**

500 V eff  
250 V eff (only for version with outer sheath diameter 3 mm, 1xPt100/4-wire connection, 2xPt100/3-wire connection)  
at temperature (20 ±15)°C, max. 80 % relative humidity

**Electrical insulation resistance:**

min. 100 MΩ according to EN 60751,  
at temperature (25 ±10)°C, max. 80 % relative humidity

**Thermocouple sensors type T1570**

**Thermocouple:**

1x / 2x "J", "K", "N"  
accuracy class 1, 2 according to IEC 584-2

**Measuring range:**

-200 to +800 °C ("J")  
-200 to +1300 °C ("K", "N")

**Output signal:**

without transmitter voltage  
with transmitter linearized 4 to 20 mA

**Dielectric strength:**

500 V eff (including version "1xJ", 1x"K", 1x"N" with outer sheath diameter 3 mm)  
250 V eff (only for version "2xJ", 2x"K", 2x"N" with outer sheath diameter 3 mm)  
at temperature (20 ±15)°C, max. 80 % relative humidity

**Electrical insulation resistance:**

min. 1000 MΩ according to EN 61515,  
at temperature (20 ±15)°C, max. 80 % relative humidity

**Standard version of measuring junction:**

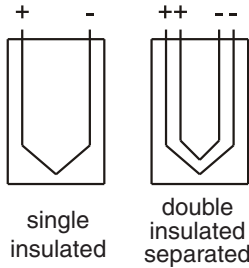

**Materials:**

*head* - aluminium alloy (codes H1, H2, H3, H4(N), H5(N), H6)  
- stainless steel 1.4541(AISI 321) (code H7)  
- polyamide (code H5PA)

*stem of measuring insert*

Pt100 - stainless steel 1.4404 (AISI 316L)  
"J" - stainless steel 1.4541 (AISI 321)  
"K", "N" - alloy Inconel 600, Microbell/Pyrosil

*RTD inside wiring* - Cu, Ni

*extension piece* - stainless steel 1.4541 (AISI 321),  
(codes J13, J16, J21P, J23, J32, J33, J43, J63)

*thermowells* - stainless steel 1.4541 (AISI 321),  
(codes J23, J32, J32, J63)

*protective tube*

- stainless steel 1.4541 (AISI 321),  
(codes B53, B63, B73, B83)  
- heat-resisting steel 1.4845 (AISI 310)  
(codes B64, B74, B84, B84Z, B842, B843)  
- heat-resisting steel 1.4762 (AISI 446)  
(codes B85, B852, B853)  
- Kanthal AF (codes B66, B86)

**Housing (according to EN 60529):**

IP 65, IP 68 (according to used head)

**General**

**Response time:**

**Resistance sensors type T1070**

Version J43, B00, B01

Stem diameter [mm]	t <sub>0,5</sub> [s]		t <sub>0,9</sub> [s]	
	water	air	water	air
3	1,5	14	4	41
4,5	3	23	9	71
6	4	38	13	118
6 with distance sleeve Ø8	9,5	89	28	280

Version J23 (thermowell 9x1)

Stem diameter [mm]	t <sub>0,5</sub> [s]		t <sub>0,9</sub> [s]	
	water	air	water	air
6	25	114	75	356

Version J33 (thermowell 11x2)

Stem diameter [mm]	t <sub>0,5</sub> [s]		t <sub>0,9</sub> [s]	
	water	air	water	air
6	32	170	96	534

**Thermoelectric sensors type T1570**

Version J43, B00, B01

Stem diameter [mm]	t <sub>0,5</sub> [s]		t <sub>0,9</sub> [s]	
	water	air	water	air
3	1	22	3	64
4,5	2,5	34	6,5	113
6	3	55	9	170

Version J23 (thermowell 9x1)

Stem diameter [mm]	t <sub>0,5</sub> [s]		t <sub>0,9</sub> [s]	
	water	air	water	air
6	9	165	27	510

Version J33 (thermowell 11x2)

Stem diameter [mm]	t <sub>0,5</sub> [s]		t <sub>0,9</sub> [s]	
	water	air	water	air
6	14	248	41	765

v<sub>water</sub> = 0.4 m/s. v<sub>air</sub> = 2 m/s

t<sub>0,5</sub> - 50 % of temperature step

t<sub>0,9</sub> - 90 % of temperature step

**Operation conditions**

**Maximal temperature of head (not for Ex version):**

100 °C (without transmitter)  
85 °C (with transmitter P5310, P5311 and 5335)

**Maximal temperature of transition between stem of measuring insert and terminal block:**

100 °C (in the short term 120 °C)



**Ambient temperature of head Ta for Ex version (codes ED, ET, EI):**

-50 ≤ Ta ≤ 85 °C temperature class T5...Tx,  
-50 ≤ Ta ≤ 75 °C temperature class T6,

**Maximal permissible operating properties of transmitter in the head for Ex version (codes ED, ET):**

I<sub>imax</sub>: 30 mA  
P<sub>imax</sub>: 1 W

**Allowable load of protective tubes (codes B63, B64, B66, B73, B74, B83, B84, B85, B86, B84Z, B842, B843, B852, B853):**

max. overpressure 100 kPa

**Completion with thermowells for sensors designed for installation into thermowells:**

WT70 C Thermowell, cylindrical, PN 160, for screwing, for welding, with flange, inner bore 9; 7; 5; 3.5 mm, optional outer connection and inner thread, optional nominal length and material

WT70 T Thermowell, conical, PN 400, for screwing, inner bore 9; 6.25; 3.2 mm, optional inner and outer thread, optional nominal length and material

WT70 D Thermowell, conical, according to DIN 43772, PN 250, for welding, with flange, inside bore 9; 7; 3.5 mm, optional inner and outer thread, nominal length and material

Optional protective coating, wide range of accessories. Detailed information can be found in data sheet No. 0993.

**Surface temperature for Ex version (code ED, ET, EI):**



User is obliged to ensure installation of temperature sensors in such a way, that there is no influence of external heat sources (measured medium, sun heating, etc.) on the surface of the sensor and its fittings that could lead to exceeding defined maximum surface temperature defined in EN 60079-0. When defining a surface temperature of the sensor, it has to be calculated with a 5 °C for heating of the sensor from possible maximum operating energy output ( $P_{imax} = 1 \text{ W}$ ).

Maximal surface temperatures for electrical devices group II for explosion hazard environment of gases, vapors and mists according to EN 60079-14 are listed in the following table. The maximal surface temperature for electrical equipment group II for explosion hazard environment of dusts according to EN 60079-14 is given by the smaller of the values defined in the following points:

- a) ignition temperature of dust in layer decreased by 75 °C,
- b) 2/3 of ignition temperature of dust in turbulent state.

Temperature class	Maximal surface temperature	Max. temperature of measured medium
T1	450 °C	440 °C
T2	300 °C	290 °C
T3	200 °C	195 °C
T4	135 °C	130 °C
T5	100 °C	95 °C
T6	85 °C	80 °C

For process temperature (measured medium)  $440 \text{ °C} < T_m \leq 1200 \text{ °C}$ , the maximal surface temperature of sensor  $T_x$  is determined from maximal temperature of the process (measured medium)  $T_m$  and safety addition  $10 \text{ °C}$ .

$$T_x = T_m + 10 \text{ °C}$$

Maximal surface temperature  $T_x$  for dust explosive atmosphere is equal to measured medium temperature  $T_m$ .

$$T_x = T_m$$

**Supplementary parameters**

**EMC (Electromagnetic compatibility):**

according to EN 61326-1

**EC Certificate on type examination, No. FTZÚ 03 ATEX 0297X with appendix No. 5 dated 16.4.2018.**

For explosion hazard environment of gasses and dusts are approved these versions:

Versions with thermowell

T1070/T1570..J23/J32/J33/J63/J99..H6/H7..ED/ET

and straight versions

T1070/T1570..B53/B63/B64/B66/B73/B74/B83/B84/B85/B86/B84Z/B842/B843/B852/B853/B99..H6/H7..ED/ET

with marking:



II 1/2G Ex da/db IIC T6...Tx°C Ga/Gb

II 1/2D Ex ta/tb IIIC T90°C...Tx°C Da/Db

Versions into thermowell T1070/T1570..J13/J16/J21P/J19..H6/H7..ED/ET

with marking:



II 2G Ex db IIC T6...Tx°C Gb

II 2D Ex tb IIIC T90°C...Tx°C Db

Spatial version T1070..P1E..H6/H7..ED/ET

with marking:



II 2G Ex db IIC T5/T6 Gb

II 2D Ex tb IIIC T90°C Db

**EC Certificate on type examination, No. FTZÚ 13 ATEX0080X dated 25.6.2018.**

For explosion hazard environment of gasses and dusts are approved these versions:

Versions into thermowell T1070/T1570..J13/J16/J21P/J19..H5/H5N/H6/H7..EI

with marking:



II 2G Ex ia IIC T6...Tx°C Gb

II 1/2D Ex ia IIIC T 85°C...Tx°C Da/Db

Spatial version T1070..P1E..H5/H5N/H6/H7..EI

with marking:



II 2G Ex ia IIC T6...Tx°C Gb

II 1D Ex ia IIIC T 85°C...Tx°C Da

Other standard versions

T1070/T1570..(except J13 and P1E)..H5/H5N/H6/H7..EI

with marking:



II 1/2G Ex ia IIC T6...Tx°C Ga/Gb

II 1D Ex ia IIIC T 85°C...Tx°C Da

**CAUTION!**

In addition to specified cable glands, it is possible to use for the sensors also other cable glands with connection thread M20x1.5 and with individual approval for specific type of protection. Cable gland must meet the requirements of EN 60079-1.

When using cable glands (code KME1, KME2) designed for fixed cable installation, the cable shall be fixed against a possible rotation and displacements. Cable gland provides proper protection if it is correctly tight and used with sealing.

**Any intervention into construction of the sensor with a ED, ET or EI version is not permitted as may cause an explosion!**

Sensor weight T1070 and T1570 [kg]										
Sensor version without transmitter with head H1	J13	J23		J33		J43	B00, B01	B63	B64	
	with extension piece	without extension piece	with extension piece	with screwing	with flange	without thermowell	without fitting	straight with dia. 14	straight with dia. 14	
Nominal length										
L100	0.52	0.37	0.47	0.65	1.5	0.52	--	--	--	
L110	--	--	--	--	--	--	0.32	--	--	
L160	0.53	0.38	0.49	0.7	1.54	0.53	--	--	--	
L170	--	--	--	--	--	--	0.33	--	--	
L230	--	0.39	--	--	--	--	--	--	--	
L240	--	--	--	--	--	--	0.34	--	--	
L250	0.55	--	0.53	0.75	1.59	0.55	--	0.69	0.69	
L300	--	--	--	--	--	--	0.35	--	--	
L310	--	--	--	--	--	--	--	0.8	0.8	
L380	--	0.42	--	--	--	--	--	--	--	
L390	--	--	--	--	--	--	0.37	--	--	
L400	0.58	--	0.58	0.8	1.68	0.58	--	0.98	0.98	
L500	--	--	--	--	--	--	0.39	1.17	1.17	
L530	--	0.46	--	--	--	--	--	--	--	
L540	--	--	--	--	--	--	0.4	--	--	
L630	0.63	--	0.63	0.95	1.82	0.63	--	--	--	
L710	--	--	--	--	--	--	0.42	1.57	1.57	
L770	--	--	--	--	--	--	0.43	--	--	
L800	--	--	--	--	--	--	--	1.75	1.75	
L1000	--	--	--	--	--	--	0.48	2.14	2.14	
L1400	--	--	--	--	--	--	0.55	2.91	2.91	
L1600	--	--	--	--	--	--	--	3.3	3.3	
L2000	--	--	--	--	--	--	0.66	4.08	4.08	
L999	--	--	--	--	--	--	--	--	--	
<b>Head weight [kg]</b>										
H2					0.04					
H3					0.05					
H4, H5				0.2				--	0.2	
H6				0.16				--	0.16	
H7				0.7				--	0.7	
H9					--					
<b>Transmitter weight [kg]</b>										
P5310					0.04					
P5311					0.05					
5335					0.05					

Dimensional drawings

Resistance and thermocouple measuring inserts with mineral isolation

Cold-end

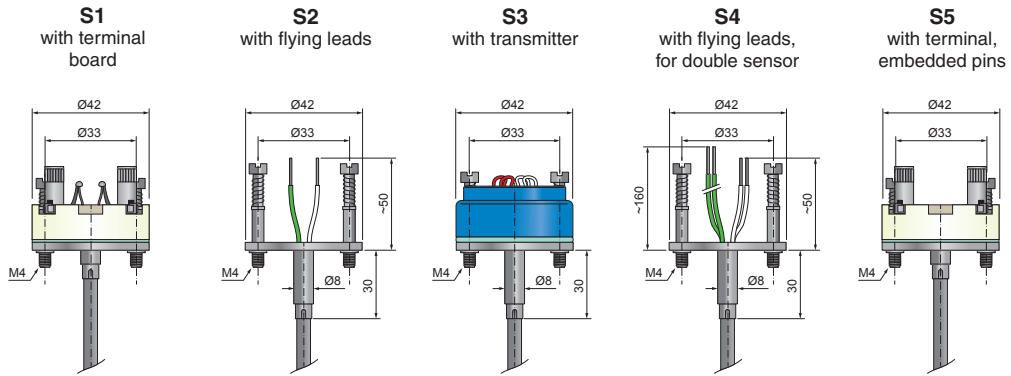

Measuring-end

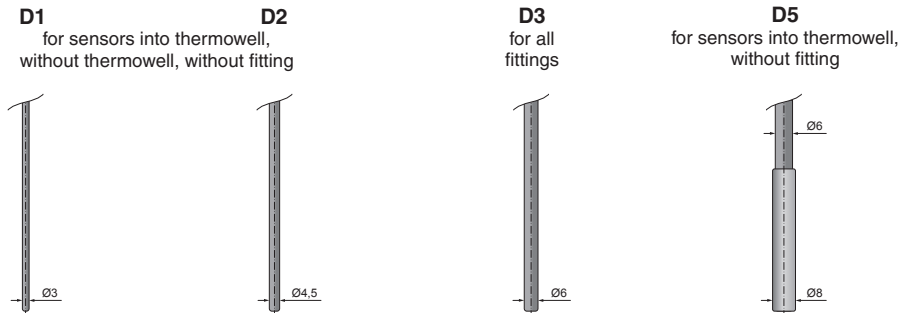

Head

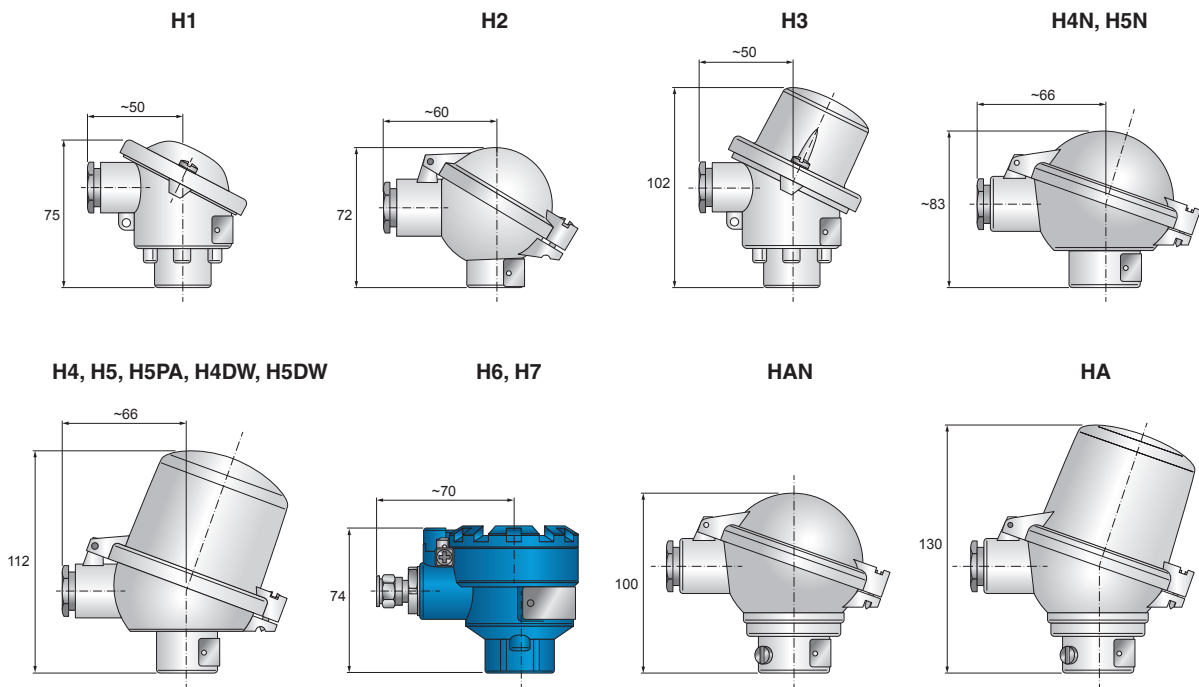

Fittings

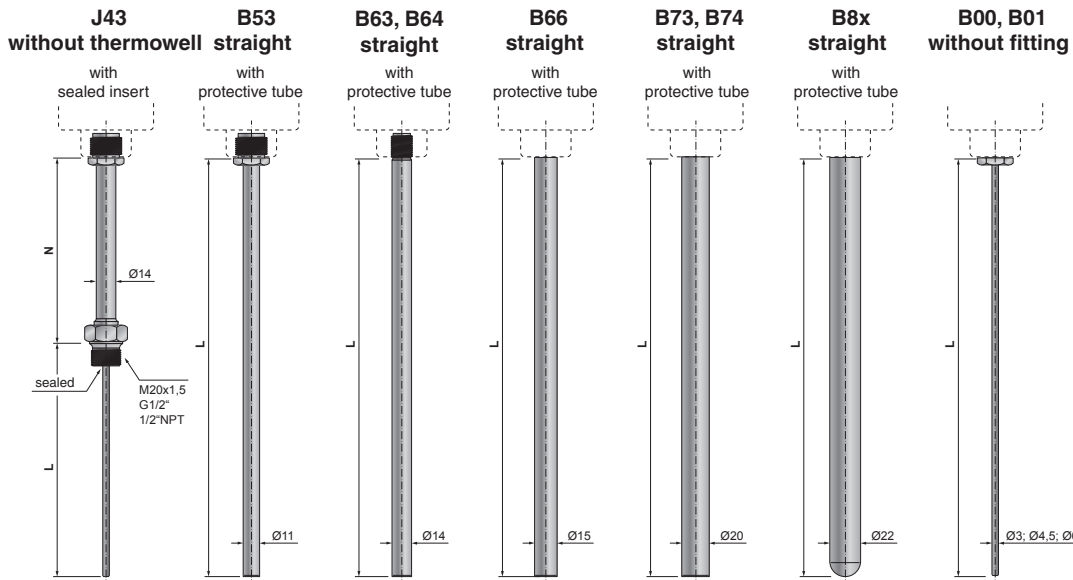
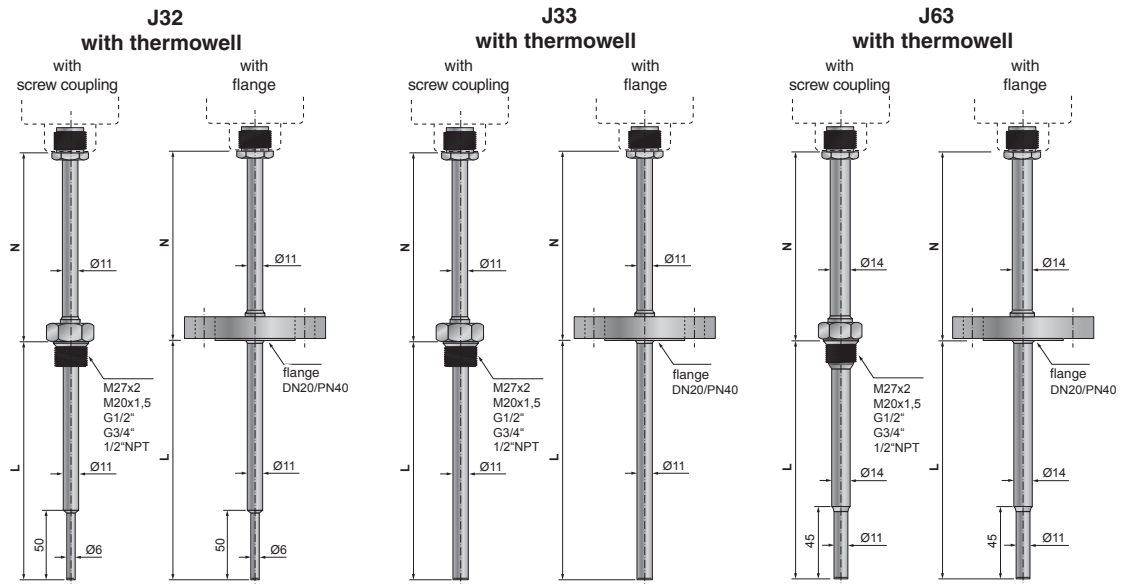
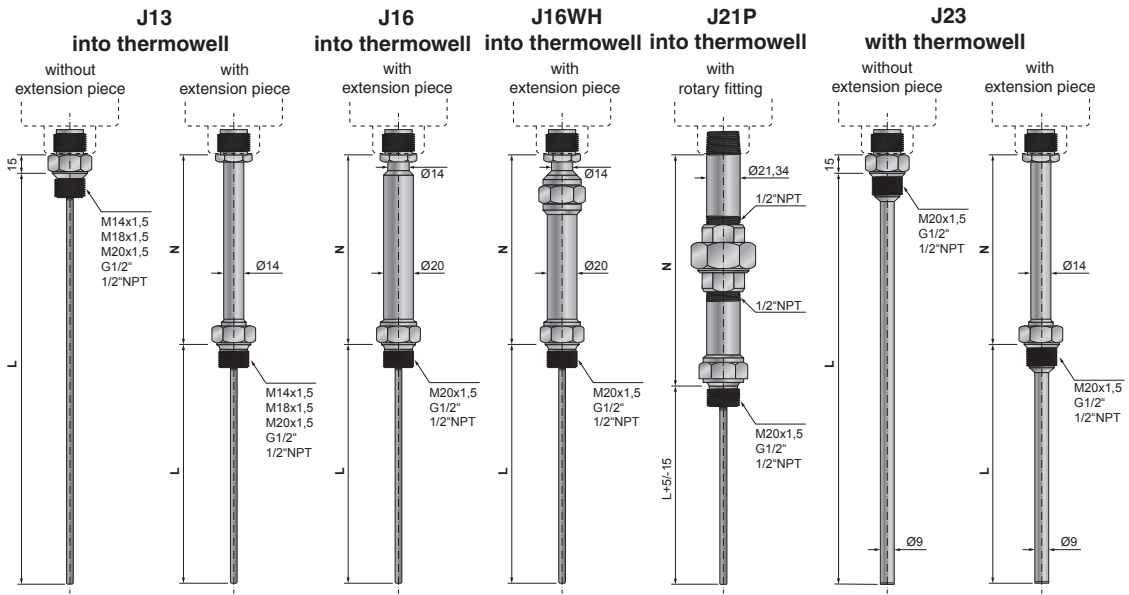

Thermowells

WT70 C, for screwing

WT70 C 01 V900 ...

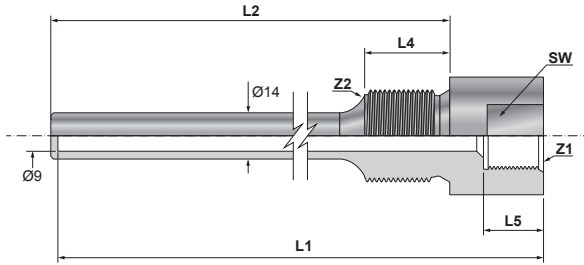

WT70 C 01 V700 ...

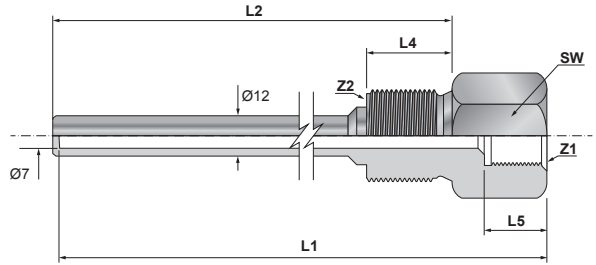

WT70 C 01 V625 ...

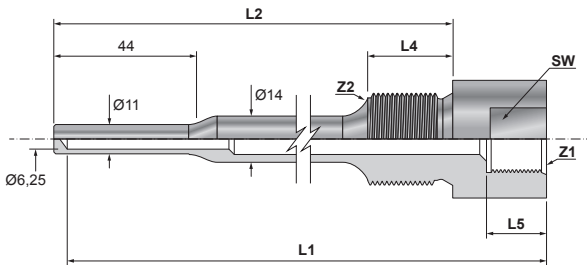

WT70 C 01 V350 / V500 ...

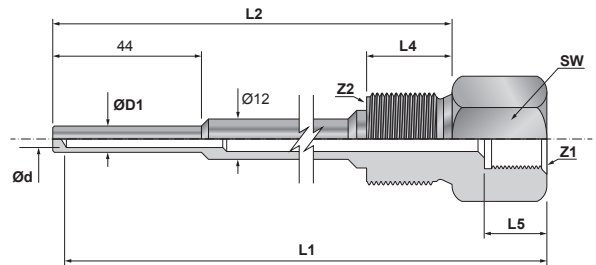

WT70 C, for welding

WT70 C 02 V900 ...

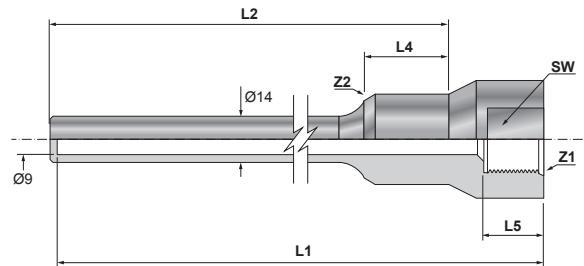

WT70 C 02 V700 ...

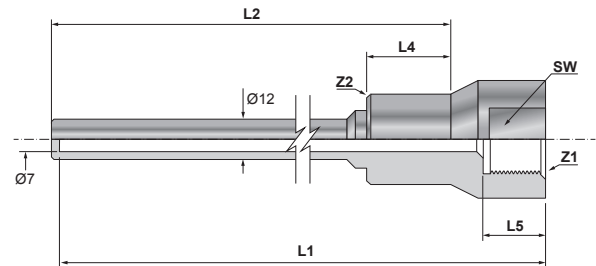

WT70 C 02 V625 ...

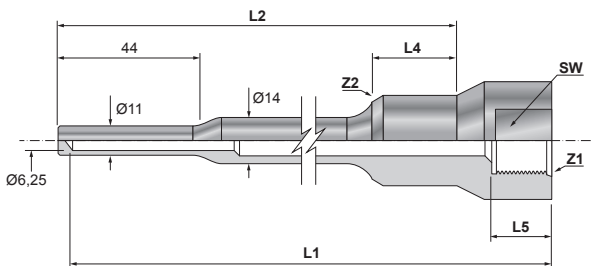

WT70 C 02 V350 / V500 ...

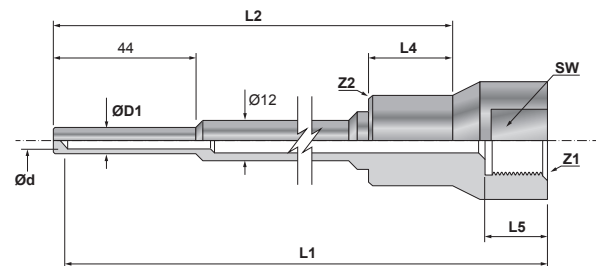

**WT70 C, with flange**

WT70 C 03 V900 ...

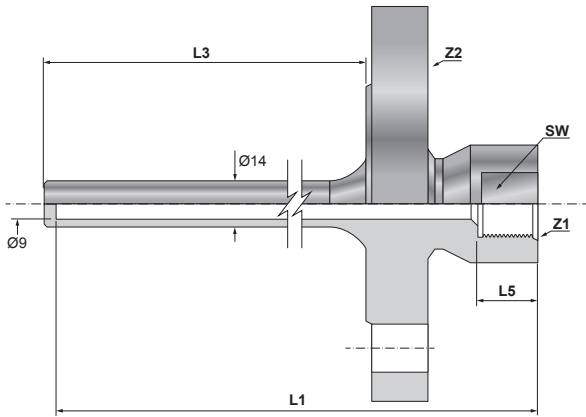

WT70 C 03 V700 ...

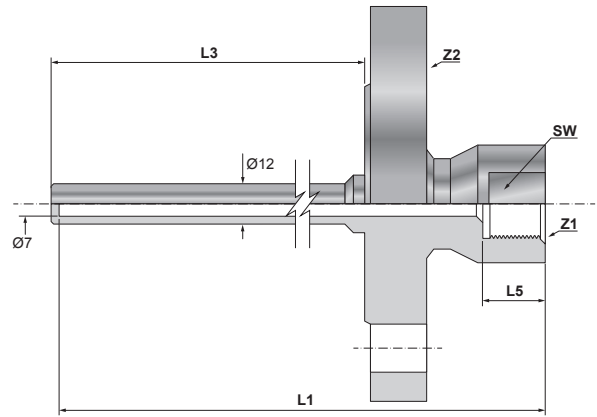

WT70 C 03 V625 ...

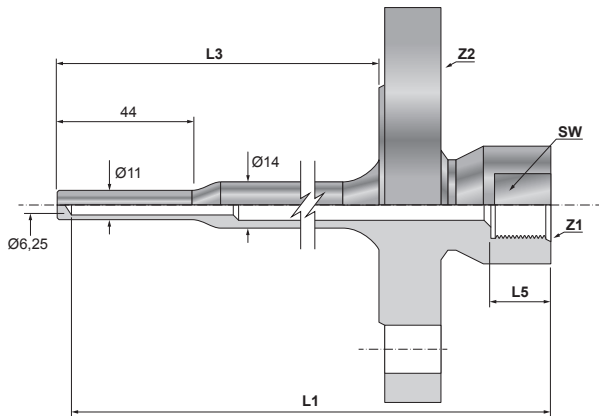

WT70 C 03 V300 / V500 ...

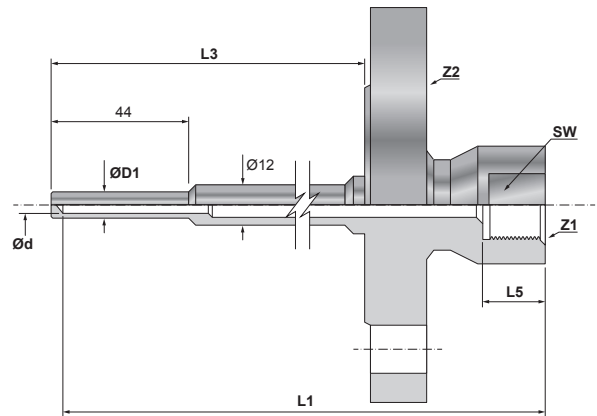

**WT70 C, between flanges**

WT70 C 03 ... P89

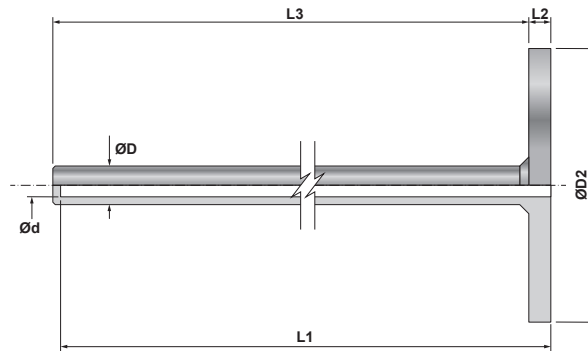

**WT70 T, for screwing**

WT70 T 21 V900 ...

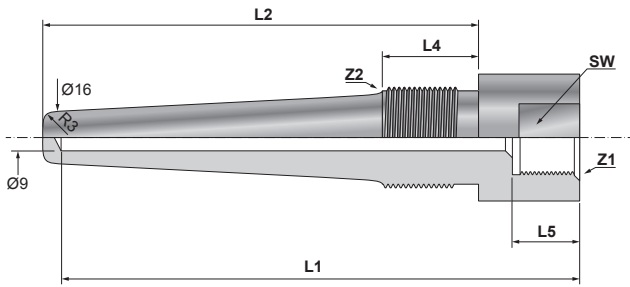

WT70 T 21 V625 ...

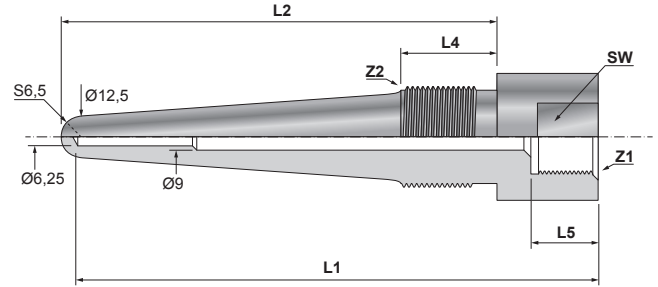

WT70 T 21 V320 ...

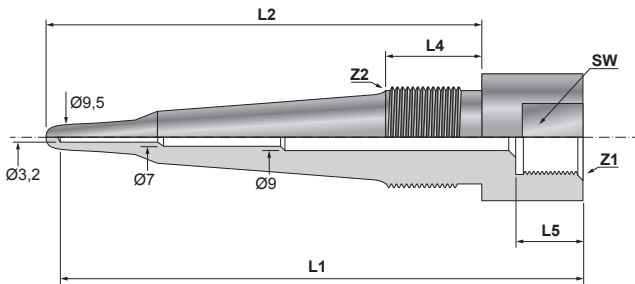

**WT70 D, for welding**

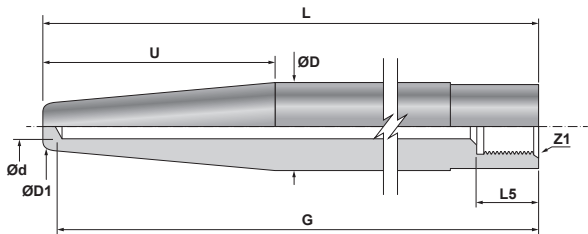

**WT70 D, with flange**

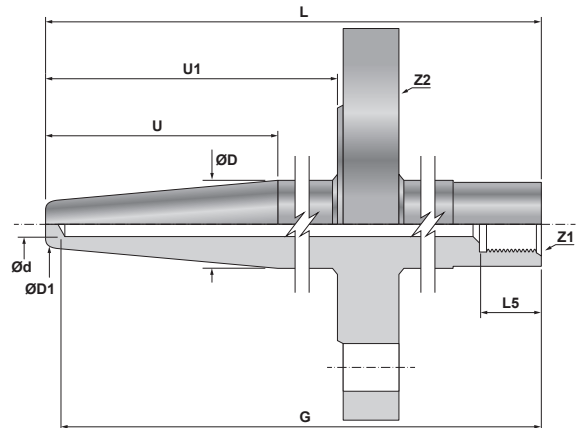

**NV Welded on piece for WT70 C and WT70 T**

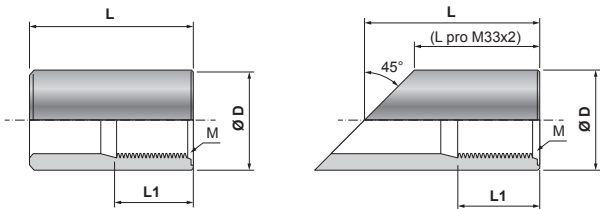

**NV D Welded on piece for WT70 D**

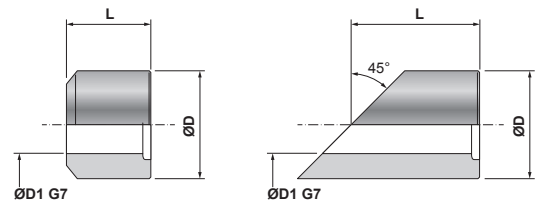

**NT70 Extension piece for temperature sensors**

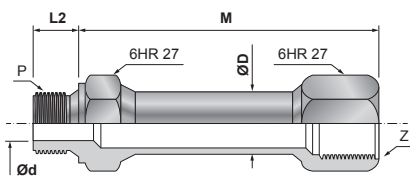

## Electrical connection

### a) RTD

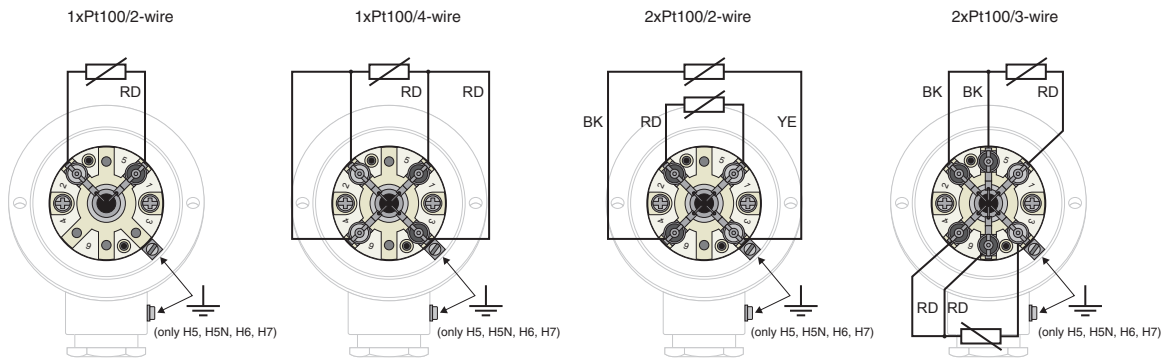

### b) TC

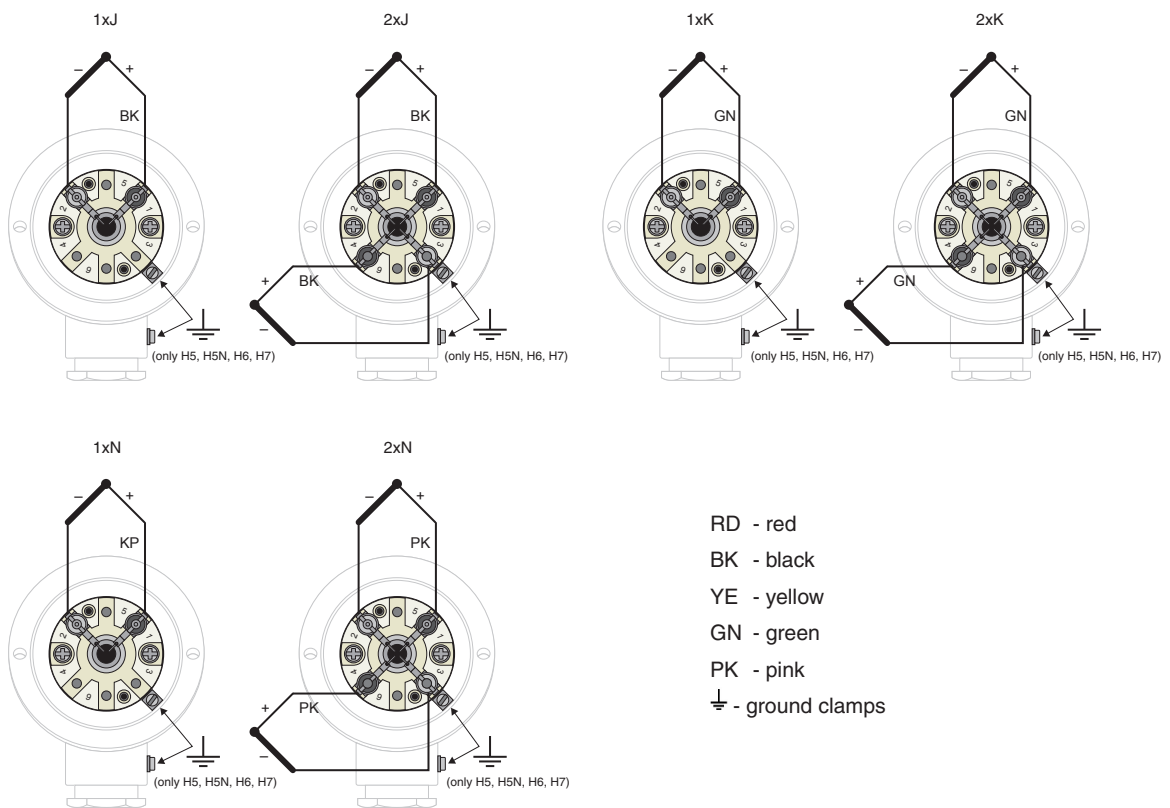

**ModuTEMP® 70 - Sensors with thermowell**

Table 1

Type	Description		
o T1070	Resistance temperature sensor with thermowell		
o T1570	Thermocouple temperature sensor with thermowell		
Code	Temperature sensor		
	<i>Resistance (RTD)</i>	<i>Sheath material</i>	<i>Max. temperature of use</i>
o 04	1xPt100, two-wire inside wiring	1.4404	up to 500 °C
o 06	1xPt100, four-wire inside wiring	1.4404	up to 600 °C
06HT	1xPt100, four-wire inside wiring	Inconel 600	up to 700 °C - only for code F7
o 07	2xPt100, three-wire inside wiring	1.4404	up to 600 °C
08	2xPt100, two-wire inside wiring	1.4404	up to 500 °C
09	2xPt100, four-wire inside wiring	1.4404	up to 600 °C - only for codes S4 and S5
...VR	Increased resistance to vibration and shock		
	<i>Thermocouple (TC)</i>	<i>Sheath material</i>	<i>Measuring range</i>
o 21	1x"J" (Fe-CuNi), insulated	1.4541	-200 to +800 °C
o 61	2x"J" (Fe-CuNi), insulated, isolated junctions	1.4541	-200 to +800 °C
o 22	1x"K" (NiCr-NiAl), insulated	Inconel 600	-200 to +1100 °C
o 62	2x"K" (NiCr-NiAl), insulated, isolated junctions	Inconel 600	-200 to +1100 °C
23	1x"N" (NiCrSi-NiSi), insulated	Inconel 600	-200 to +1100 °C
63	2x"N" (NiCrSi-NiSi), insulated, isolated junctions	Inconel 600	-200 to +1100 °C
22HT	1x"K" (NiCr-NiAl), insulated	Nicrobell/Pyrosil	-200 to +1300 °C
62HT	2x"K" (NiCr-NiAl), insulated, isolated junctions	Nicrobell/Pyrosil	-200 to +1300 °C
23HT	1x"N" (NiCrSi-NiSi), insulated	Nicrobell/Pyrosil	-200 to +1300 °C
63HT	2x"N" (NiCrSi-NiSi), insulated, isolated junctions	Nicrobell/Pyrosil	-200 to +1300 °C
...U	Grounded version of junction TC		
99	Other		
Code	Accuracy class	Inside wiring materia	Measuring range
	<i>Resistance (RTD) according to EN 60751</i>		
o F1	B	Cu	-50 to +300 °C - not for code 06HT
o F2	B	Cu	-70 to +500 °C - not for code 06HT
o F3	B	Ni <sup>1)</sup>	-200 to +600 °C - only for codes 06, 07 and 09
o F7	B	Ni <sup>1)</sup>	-200 to +700 °C - only for code 06HT
o F4	A	Cu	-30 to +300 °C - only for codes 06, 07 and 09
o F5	A	Cu	-100 to +450 °C - only for codes 06, 07 and 09
F9	Other		
	<i>Thermocouple (TC) according to EN 60584-1</i>		
o T7	2		
o T6	1		
T9	Other		
Code	Fitting of the sensor <sup>2)</sup>	Diameter of extension piece	Fitting material
o J23	With thermowell Ø 9 x 1 mm, PN 63	14 x 2.5 mm	1.4541
o J32	With thermowell Ø 11 x 2 mm reduced to Ø 6 x 1.3 mm, PN 100	11 x 2 mm	1.4541
o J33	With thermowell Ø 11 x 2 mm, PN 100	11 x 2 mm	1.4541
o J63	With thermowell Ø 14 x 2.5 mm reduced to Ø 11 x 2.4 mm, PN 160	14 x 2.5 mm	1.4541
J99	Other with thermowell		
Code	Nominal immersion of sensor L [mm]		
o L100	100		
o L160	160		
o L250	250 - not for J23 N000		
o L400	400 - not for J23 N000		
o L630	630 - not for J23 N000		
o L230	230 - only for J23 N000		
o L380	380 - only for J23 N000		
o L530	530 - only for J23 N000		
L...	Other (please fill nominal immersion of sensor in mm)		
Code	Head		
o H1	Al alloy, cable outlet M20x1.5 for cable Ø 4 to 12.5 mm, IP 65		
o H2	Al alloy, cable outlet M20x1.5 for cable Ø 4 to 12.5 mm, IP 65		
o H3	Al alloy, with high cap for mounting of transmitter with Ø 44 mm, cable outlet M20x1.5 for cable Ø 4 to 12.5 mm, IP 65		
o H4N	Al alloy, with low cap, cable outlet M20x1.5 for cable Ø 4 to 12.5 mm, IP 65		
o H4	Al alloy, with high cap for mounting of transmitter with Ø 62 mm, cable outlet M20x1.5 for cable Ø 4 to 12.5 mm, IP 65		
o H5N	Al alloy, with low cap, ground clamps, cable outlet M20x1.5 for cable Ø 5 to 10 m, IP 65		
o H5	Al alloy, with high cap for mounting of transmitter with Ø 62 mm, ground clamps, cable outlet M20x1.5 for cable Ø 5 to 10 mm, IP 65		
o H5PA	Polyamide, with high cap for mounting of transmitter with Ø 62 mm, Tmax 80 °C, cable outlet M20x1.5 for cable Ø 4 to 12.5 mm, IP 65		
o H6	Al alloy, ground clamps, thread for cable outlet M20x1.5, IP 68		
o H7	Stainless steel, ground clamps, thread for cable outlet M20x1.5, IP 68		
...D	Double cable outlet - only for codes H4, H4N, H5, H5N		
...W	Sensor head with peephole for display - only for codes H4 Z1, H4D Z1, H5 Z1E and S2, S3; not for double sensors		
H9	Other		
Code	Cold-end of measuring insert		
o S1	With ceramic terminal block (diameter 42 mm) on flange of measuring insert		
o S2	For single sensor, without terminal block, with set for mounting of transmitter on flange of measuring insert (instead of terminal block)		
o S3	For single sensor, with mounted selected transmitter on flange of measuring insert (necessary specifications of transmitter)		
o S4	For double sensor, without terminal block, with set for mounting of two transmitters (not suitable for H1, H2, H5N, H6 and H7)		
o S5	With ceramic terminal block (diameter 42 mm), embedded pins (according to NAMUR)		
S9	Other		
Code	Extension piece /Nominal length of extension piece N/	Max. temperature of connection thread	
o N000 <sup>3)</sup>	Without extension piece N=15 mm (only for J23)	120 °C	
o N145	With extension piece N=145 mm	600 °C	
N...	Other (please fill nominal length of extension piece in mm)		

# Modular Resistance and Thermocouple Temperature Sensors without/with Transmitter ModuTEMP® 70

Process connection	
<b>Code</b>	<b>J23, J33, J63</b>
◦ P3	Male thread M20x1.5
◦ P4	-
◦ P5	Male thread G1/2"
◦ P6	-
◦ P7	Male thread 1/2"NPT
◦ P8	-
P9	Other
<b>OPTIONAL ACCESSORIES</b>	
<b>Code</b>	<b>Versions for explosive atmosphere of gasses or dusts</b>
	<i>Flameproof enclosure "Ex d" only for gasses and protection by enclosure "Ex t" only for dusts, intrinsically safe version "Ex i" for gasses and dusts</i>
◦ ED/ET	(Ex) II 1/2G Ex da/db IIC T6...Tx°C Ga/Gb (Ex) II 1/2D Ex ta/tb IIIC T90°C...Tx°C Da/Db
◦ EI	(Ex) II 1/2G Ex ia IIC T6...Tx°C Ga/Gb (Ex) II 1D Ex ia IIIC T85°C...Tx°C Da
<b>Code</b>	<b>Protective spray</b>
X01	Polyamide PA 11
X02	E-CTFE "Halar"
X03	PFA
X04	ETFE "Hyflon"
X05	PTFE
X07	Hard metal coating (Fe-Cr-Mn-Si-B-C) for abrasive medium
X08	Corundum spray for intense abrasive medium
X99	Other
<b>Code</b>	<b>Indication units</b>
Z1	LED display mounted in sensor head (only for code H4(D)W and S2, S3; operating temperature -20 to +80 °C)
Z1E	Intrinsically safe LED display in sensor head (Ex) II 2G Ex ia IIC T6 (only for codes H5W and S2, S3; operating temperature -20 to +80 °C)
<b>Code</b>	<b>Cable outlet <sup>4)</sup></b>
• KM1	Cable outlet, nickel-plated brass, IP 68, M20x1.5, for cable Ø 5 to 10 mm (standard for H6, H7)
KM4	Cable outlet, stainless steel, IP 68, M20x1.5, for cable Ø 7 to 12 mm
• KME1	Cable outlet, nickel-plated brass, Ex d, M20x1.5, IP 68, for fixed assembly cable Ø 4.5 to 8.5 mm
• KME2	Cable outlet, nickel-plated brass, Ex d, M20x1.5, IP 68, for fixed assembly cable Ø 7 to 12 mm
KME3	Cable outlet, stainless steel, Ex d, M20x1.5, IP 68, for fixed assembly cable Ø 4 to 8 mm
KME5	Cable outlet, polyamide (light blue), Ex e, M20x1.5, IP 68, for fixed assembly cable Ø 5 to 9 mm, operating temperature -20 to +95 °C (not for H5PA)
KME6	Cable outlet, polyamide (light blue), Ex e, M20x1.5, IP 68, for fixed assembly cable Ø 6.5 to 12 mm, operating temperature -20 to +95 °C (not for H5PA)
KM9	Other
• PK1	Lock anti pull-up cable for Ex d cable outlet KME1
• PK2	Lock anti pull-up cable for Ex d cable outlet KME2
<b>Code</b>	<b>Snap lock</b>
• RU	Snap lock - only with codes H2, H4, H4N, H5, H5N
<b>Code</b>	<b>Calibration in customer defined points, including certificate of calibration</b>
◦ KTE31A	Resistance temperature sensor calibration in three points in range -40 to +660 °C
◦ KTE51A	Resistance temperature sensor calibration in five points in range -40 to +660 °C
◦ KTE32AA	Thermocouple temperature sensor calibration in three points in range -40 to +660 °C
◦ KTE52AA	Thermocouple temperature sensor calibration in five points in range -40 to +660 °C
KTE9	Other
<b>Code</b>	<b>Extended warranty</b>
◦ WE36	Product warranty 36 months - not for code VR
WE..	Other (the number of months must be added to the code) - not for code VR
<b>Code</b>	<b>Accessories</b>
• BZS	Stainless steel tag for attachment (70x15 mm) with laser description according to the order
• PPZ	Laser description of sensor according to the order
• Q1	Material certificate according to EN 10204, 3.1
<b>Code</b>	<b>Transmitters for headmounting</b>
• P5310 H10	Transmitter with LHP protocol (see data sheet No. 0824)
◦ P5310EN2 H10	Transmitter with LHP protocol, (Ex) II 3G Ex nA IIC T4 Gc (see data sheet No. 0824)
• P5311 H10	Transmitter with LHP protocol with galvanic isolation (see data sheet No. 0824)
◦ P5311EN2 H10	Transmitter with LHP protocol with galvanic isolation, (Ex) II 3G Ex nA IIC T4 Gc (see data sheet No. 0824)
◦ P5311EI1 H10	Transmitter with LHP protocol with galvanic isolation, (Ex) II 1G Ex ia IIC T4-T6 Ga, (Ex) II 1D Ex ia IIIC T106°C Da (see data sheet No. 0824)
• P5315 H10	Precision transmitter with LHP protocol with galvanic isolation (see data sheet No. 2098)
P5315EN2 H10	Precision transmitter with LHP protocol with galvanic isolation, (Ex) II 3G Ex nA [ic] IIC T4 Gc (see data sheet No. 2098)
• P5320 H10	Precision transmitter with HART protocol with galvanic isolation (see data sheet No. 0825)
• P5320EN2 H10	Precision transmitter with HART protocol with galvanic isolation, (Ex) II 3G Ex nA [ic] IIC T4 Gc (see data sheet No. 0825)
P5320EI1 H10	Precision transmitter with HART protocol with galvanic isolation, (Ex) II 1G Ex ia IIC T4-T6 Ga, (Ex) II 1D Ex ia IIIC Txx°C Da (see data sheet No. 0825)
<b>Example of order: T1070 04 F2 J33 L160 H3 S1 N145 P3 KTE31A (-40, 200, 500 °C)</b>	

- ... Ex stock version      ° ... Marked version can be dispatched up to 5 working days (with calibration up to two weeks)
- 1) ... Not allowable to use two-wire connection because of nickel inner wiring.
- 2) ... max. use temperature up to +600 °C; for medium pressure up to 1 bar and for low flow velocity it can be used up to + 800 °C
- 3) ... Sensor head is NOT POSSIBLE to turn with cable outlet to the to the desired position after installation to the technology.
- 4) ... The heads H1, H2, H3, H4, H4N, H5, H5N are usually equipped with nickel-plated brass cable outlet for cable with diameter 4 to 12.5 mm.

**ModuTEMP® 70 - Sensors into thermowell**

Table 2

Type	Description				
o T1070	Resistance temperature sensor into thermowell				
o T1570	Thermocouple temperature sensor into thermowell				
Code	Temperature sensor				
	Resistance (RTD)		Sheath material	Max. temperature of use	
o 04	1xPt100, two-wire inside wiring		1.4404	up to 500 °C	
o 06	1xPt100, four-wire inside wiring		1.4404	up to 600 °C	
o 06HT	1xPt100, four-wire inside wiring		Inconel 600	up to 700 °C - only for code F7	
o 07	2xPt100, three-wire inside wiring		1.4404	up to 600 °C	
o 08	2xPt100, two-wire inside wiring		1.4404	up to 500 °C	
o 09	2xPt100, four-wire inside wiring		1.4404	up to 600 °C - only for codes S4 and S5	
o ...VR	Increased resistance to vibration and shock			up to 500 °C - only for code 06 F2 ... S5	
	Thermocouple (TC)		Sheath material	Measuring range	
o 21	1x"J" (Fe-CuNi), insulated		1.4541	-200 to +800 °C	
o 61	2x"J" (Fe-CuNi), insulated, isolated junctions		1.4541	-200 to +800 °C	
o 22	1x"K" (NiCr-NiAl), insulated		Inconel 600	-200 to +1100 °C	
o 62	2x"K" (NiCr-NiAl), insulated, isolated junctions		Inconel 600	-200 to +1100 °C	
23	1x"N" (NiCrSi-NiSi), insulated		Inconel 600	-200 to +1100 °C	
63	2x"N" (NiCrSi-NiSi), insulated, isolated junctions		Inconel 600	-200 to +1100 °C	
22HT	1x"K" (NiCr-NiAl), insulated		Nicrobell/Pyrosil	-200 to +1300 °C	
62HT	2x"K" (NiCr-NiAl), insulated, isolated junctions		Nicrobell/Pyrosil	-200 to +1300 °C	
23HT	1x"N" (NiCrSi-NiSi), insulated		Nicrobell/Pyrosil	-200 to +1300 °C	
63HT	2x"N" (NiCrSi-NiSi), insulated, isolated junctions		Nicrobell/Pyrosil	-200 to +1300 °C	
...U	Grounded version of junction TC				
99	Other				
Code	Accuracy class	Inside wiring material	Measuring range		
	Resistance (RTD) according to EN 60751				
o F1	B	Cu	-50 to +300 °C		- not for code 06HT
o F2	B	Cu	-70 to +500 °C		- not for code 06HT
o F3	B	Ni <sup>1)</sup>	-200 to +600 °C		- only for codes 06, 07 and 09
o F7	B	Ni <sup>1)</sup>	-200 to +700 °C		- only for code 06HT
o F4	A	Cu	-30 to +300 °C		- only for codes 06, 07 and 09
o F5	A	Cu	-100 to +450 °C		- only for codes 06, 07 and 09
F9	Other				
	Thermocouple (TC) according to EN 60584-1				
o T7	2				
o T6	1				
T9	Other				
Code	Fitting of the sensor	Diameter of extension piece	Fitting material	T <sub>MAX</sub>	
o J13	Into thermowell	14 x 2.5 mm	1.4541	3)	
o J16	Into thermowell	20 x 3 mm	1.4541	3)	
J16WH	Into thermowell, with 6HR 27 mm welded to the adapter under the sensor head	20 x 3 mm	1.4541	3)	
J21P	Into thermowell, with rotary fitting in the middle of extension piece <sup>2)</sup>	21.3 x 2.6 mm	1.4541	3)	
J19	Other into thermowell				
Code	Nominal immersion of sensor L [mm]				
o L100	100				
o L160	160				
o L165	165				
o L195	195				
o L250	250				
o L255	255				
o L400	400				
o L405	405				
o L630	630				
L....	Other (please fill nominal immersion of sensor in mm)				
Code	Head				
o H1	Al alloy, cable outlet M20x1.5 for cable Ø 4 to 12.5 mm, IP 65				
o H2	Al alloy, cable outlet M20x1.5 for cable Ø 4 to 12.5 mm, IP 65				
o H3	Al alloy, with high cap for mounting of transmitter with Ø 44 mm, cable outlet M20x1.5 for cable Ø 4 to 12.5 mm, IP 65				
o H4N	Al alloy, with low cap, cable outlet M20x1.5 for cable Ø 4 to 12.5 mm, IP 65				
o H4	Al alloy, with high cap for mounting of transmitter with Ø 62 mm, cable outlet M20x1.5 for cable Ø 4 to 12.5 mm, IP 65				
o H5N	Al alloy, with low cap, ground clamps, cable outlet M20x1.5 for cable Ø 5 to 10 mm, IP 65				
o H5	Al alloy, with high cap for mounting of transmitter with Ø 62 mm, ground clamps, cable outlet M20x1.5 for cable Ø 5 to 10 mm, IP 65				
o H5PA	Polyamide, with high cap for mounting of transmitter with Ø 62 mm, Tmax 80 °C, cable outlet M20x1.5 for cable Ø 4 to 12.5 mm, IP 65				
o H6	Al alloy, ground clamps, thread for cable outlet M20x1.5, IP 68				
o H7	Stainless steel, ground clamps, thread for cable outlet M20x1.5, IP 68				
...D	Double cable outlet		- only for codes H4, H4N, H5, H5N		
...W	Sensor head with peephole for display		- only for codes H4 Z1, H4D Z1, H5 Z1E and S2, S3; not for double sensors		
H9	Other				
Code	Cold-end of measuring insert				
o S1 <sup>4)</sup>	With ceramic terminal block (diameter 42 mm) on flange of measuring insert (only for diameter 6 mm (code D3, D5))				
o S2 <sup>4)</sup>	For single sensor, without terminal block, with set for mounting of transmitter on flange of measuring insert (instead of terminal block)				
o S3 <sup>4)</sup>	For single sensor, with mounted selected transmitter on flange of measuring insert (necessary specifications of transmitter)				
o S4 <sup>5)</sup>	For double sensor, without terminal block, with set for mounting of two transmitters (not suitable for H1, H2, H5N, H6 and H7)				
o S5	With ceramic terminal block (diameter 42 mm), embedded pins (according to NAMUR)				
S9	Other				
Code	Measuring insert diameter [mm]				
o D1 <sup>5)</sup>	Ø 3				
o D2 <sup>5)</sup>	Ø 4.5 (only for TC)				
o D3	Ø 6				
o D5	Ø 6 with distance sleeve Ø 8				
D9	Other				

# Modular Resistance and Thermocouple Temperature Sensors without/with Transmitter ModuTEMP® 70

Code	Extension piece /Nominal length of extension piece N/	Max. temperature of connection thread
o N000 <sup>5)</sup>	Without extension piece N=15 mm	120 °C
o N140	With extension piece N=140 mm	600 °C
o N145	With extension piece N=145 mm	600 °C
N...	Other (please fill nominal length of extension piece in mm)	
<b>Process connection</b>		
Code	J13	J16, J21P
P1	Male thread M14x1.5	-
P2	Male thread M18x1.5	-
o P3	Male thread M20x1.5	Male thread M20x1.5
o P5	Male thread G1/2"	Male thread G1/2"
o P7	Male thread 1/2"NPT	Male thread 1/2"NPT
P9	Other	Other
<b>OPTIONAL ACCESSORIES</b>		
Code	Versions for explosive atmosphere of gasses or dusts	
	<i>Flameproof enclosure "Ex d" only for gasses and protection by enclosure "Ex t" only for dusts, intrinsically safe version "Ex i" for gasses and dusts</i>	
o ED/ET	(Ex) II 2G Ex db IIC T6...Tx°C Gb (Ex) II 2D Ex tb IIIC T90°C...Tx°C Db	- only for version with heads codes H6, H7
o EI	(Ex) II 2G Ex ia IIC T6...Tx°C Gb (Ex) II 1/2D Ex ia IIIC T85°C...Tx°C Da/Db	- only for version with heads codes H5, H5N, H6, H7
Code	Indication units	
Z1	LED display mounted in sensor head (only for code H4(D)W and S2, S3; operating temperature -20 to +80 °C)	
Z1E	Intrinsically safe LED display in sensor head (Ex) II 2G Ex ia IIC T6 (only for codes H5W and S2, S3; operating temperature -20 to +80 °C)	
Code	Cable outlet <sup>7)</sup>	
• KM1	Cable outlet, nickel-plated brass, IP 68, M20x1.5, for cable Ø 5 to 10 mm (standard for H6, H7)	
KM4	Cable outlet, stainless steel, IP 68, M20x1.5, for cable Ø 7 to 12 mm	
• KME1	Cable outlet, nickel-plated brass, Ex d, M20x1.5, IP 68, for fixed assembly cable Ø 4.5 to 8.5 mm	
• KME2	Cable outlet, nickel-plated brass, Ex d, M20x1.5, IP 68, for fixed assembly cable Ø 7 to 12 mm	
KME3	Cable outlet, stainless steel, Ex d, M20x1.5, IP 68, for fixed assembly cable Ø 4 to 8 mm	
KME5	Cable outlet, polyamide (light blue), Ex e, M20x1.5, IP 68, for fixed assembly cable Ø 5 to 9 mm, operating temperature -20 to +95 °C (not for H5PA)	
KME6	Cable outlet, polyamide (light blue), Ex e, M20x1.5, IP 68, for fixed assembly cable Ø 6.5 to 12 mm, operating temperature -20 to +95 °C (not for H5PA)	
KM9	Other	
• PK1	Lock anti pull-up cable for Ex d cable outlet KME1	
• PK2	Lock anti pull-up cable for Ex d cable outlet KME2	
Code	Snap lock	
• RU	Snap lock - only with codes H2, H4, H4N, H5, H5N	
Code	Calibration in customer defined points, including certificate of calibration	
o KTE31A	Resistance temperature sensor calibration in three points in range -40 to +660 °C	
o KTE51A	Resistance temperature sensor calibration in five points in range -40 to +660 °C	
o KTE32AA	Thermocouple temperature sensor calibration in three points in range -40 to +660 °C	
o KTE52AA	Thermocouple temperature sensor calibration in five points in range -40 to +660 °C	
o KTE32AB	Thermocouple temperature sensor calibration in three points in range -40 to +1100 °C	
o KTE52AB	Thermocouple temperature sensor calibration in five points in range -40 to +1100 °C	
o KTE32B	Thermocouple temperature sensor calibration in three points in range +400 to +1300 °C	
o KTE52B	Thermocouple temperature sensor calibration in five points in range +400 to +1300 °C	
KTE9	Other	
Code	Extended warranty	
o WE36	Product warranty 36 months - not for code VR	
WE..	Other (the number of months must be added to the code) - not for code VR	
Code	Accessories	
• BZS	Stainless steel tag for attachment (70x15 mm) with laser description according to the order	
• PPZ	Laser description of sensor according to the order	
• Q1	Material certificate according to EN 10204, 3.1	
Code	Transmitters for headmounting	
• P5310 H10	Transmitter with LHP protocol (see data sheet No. 0824)	
o P5310EN2 H10	Transmitter with LHP protocol, (Ex) II 3G Ex nA IIC T4 Gc (see data sheet No. 0824)	
• P5311 H10	Transmitter with LHP protocol with galvanic isolation (see data sheet No. 0824)	
o P5311EN2 H10	Transmitter with LHP protocol with galvanic isolation, (Ex) II 3G Ex nA IIC T4 Gc (see data sheet No. 0824)	
o P5311E1 H10	Transmitter with LHP protocol with galvanic isolation, (Ex) II 1G Ex ia IIC T4-T6 Ga, (Ex) II 1D Ex ia IIIC T106°C Da (see data sheet No. 0824)	
• P5315 H10	Precision transmitter with LHP protocol with galvanic isolation (see data sheet No. 2098)	
P5315EN2 H10	Precision transmitter with LHP protocol with galvanic isolation, (Ex) II 3G Ex nA [ic] IIC T4 Gc (see data sheet No. 2098)	
• P5320 H10	Precision transmitter with HART protocol with galvanic isolation (see data sheet No. 0825)	
• P5320EN2 H10	Precision transmitter with HART protocol with galvanic isolation, (Ex) II 3G Ex nA [ic] IIC T4 Gc (see data sheet No. 0825)	
P5320E1 H10	Precision transmitter with HART protocol with galvanic isolation, (Ex) II 1G Ex ia IIC T4-T6 Ga, (Ex) II 1D Ex ia IIIC Txx°C Da (see data sheet No. 0825)	
Code	Thermowells and welded on pieces	
• WT70 C	Cylindric thermowell to screwing, to welding, with flange, PN 160 (see data sheet No. 0993)	
WT70 D	Conical thermowell to welding according to DIN 43772, PN 250 (see data sheet No. 0993)	
WT70 T	Conical thermowell to screwing, PN 400 (see data sheet No. 0993)	
• NV	Welded on piece for thermowells WT70 C, WT70 D and WT70 T (see data sheet No. 0993)	
Example of order: T1070 04 F2 J13 L160 H3 S1 D3 N145 P3 KTE31A (-40, 200, 500 °C)		

- <sup>1)</sup> ... Ex stock version      <sup>2)</sup> ... Marked version can be dispatched up to 5 working days (with calibration up to two weeks)  
<sup>3)</sup> ... Not allowable to use two-wire connection because of nickel inner wiring.      <sup>4)</sup> ... Spring stroke of insert 15 mm.  
<sup>5)</sup> ... Max. temperature of connection thread is 600 °C.      <sup>6)</sup> ... In the case of J21 direct mounting to the sensor head.      <sup>7)</sup> ... Not for J21P.  
<sup>8)</sup> ... Sensor head is NOT POSSIBLE to turn with cable outlet to the to the desired position after installation to the technology.  
<sup>9)</sup> ... The heads H1, H2, H3, H4, H4N, H5, H5N are usually equipped with nickel-plated brass cable outlet for cable with diameter 4 to 12.5 mm.

**ModuTEMP® 70 - Sensors without thermowell**

Table 3

Type	Description			
o T1070	Resistance temperature sensor without thermowell			
o T1570	Thermocouple temperature sensor without thermowell			
Code	Temperature sensor			
	<i>Resistance (RTD)</i>	<i>Sheath material</i>	<i>Max. temperature of use</i>	
o 04	1xPt100, two-wire inside wiring	1.4404	up to 500 °C	
o 06	1xPt100, four-wire inside wiring	1.4404	up to 600 °C	
06HT	1xPt100, four-wire inside wiring	Inconel 600	up to 700 °C	- only for code F7
o 07	2xPt100, three-wire inside wiring	1.4404	up to 600 °C	
08	2xPt100, two-wire inside wiring	1.4404	up to 500 °C	
09	2xPt100, four-wire inside wiring	1.4404	up to 600 °C	- only for code S4
	<i>Thermocouple (TC)</i>	<i>Sheath material</i>	<i>Measuring range</i>	
o 21	1x"J" (Fe-CuNi), insulated	1.4541	-200 to +800 °C	
o 61	2x"J" (Fe-CuNi), insulated, isolated junctions	1.4541	-200 to +800 °C	
o 22	1x"K" (NiCr-NiAl), insulated	Inconel 600	-200 to +1100 °C	
o 62	2x"K" (NiCr-NiAl), insulated, isolated junctions	Inconel 600	-200 to +1100 °C	
23	1x"N" (NiCrSi-NiSi), insulated	Inconel 600	-200 to +1100 °C	
63	2x"N" (NiCrSi-NiSi), insulated, isolated junctions	Inconel 600	-200 to +1100 °C	
22HT	1x"K" (NiCr-NiAl), insulated	Nicrobell/Pyrosil	-200 to +1300 °C	
62HT	2x"K" (NiCr-NiAl), insulated, isolated junctions	Nicrobell/Pyrosil	-200 to +1300 °C	
23HT	1x"N" (NiCrSi-NiSi), insulated	Nicrobell/Pyrosil	-200 to +1300 °C	
63HT	2x"N" (NiCrSi-NiSi), insulated, isolated junctions	Nicrobell/Pyrosil	-200 to +1300 °C	
...U	Grounded version of junction TC			
99	Other			
Code	Accuracy class	Inside wiring material	Measuring range	
	<i>Resistance (RTD) according to EN 60751</i>			
o F1	B	Cu	-50 to +300 °C	- not for code 06HT
o F2	B	Cu	-70 to +500 °C	- not for code 06HT
o F3	B	Ni <sup>1)</sup>	-200 to +600 °C	- only for codes 06, 07 and 09
o F7	B	Ni <sup>1)</sup>	-200 to +700 °C	- only for code 06HT
o F4	A	Cu	-30 to +300 °C	- only for codes 06, 07 and 09
o F5	A	Cu	-100 to +450 °C	- only for codes 06, 07 and 09
F9	Other			
	<i>Thermocouple (TC) according to EN 60584-1</i>			
o T7	2			
o T6	1			
T9	Other			
Code	Fitting of the sensor	Diameter of extension piece	Fitting material	
o J43	Without thermowell	14 x 2.5 mm	1.4541	
J49	Other without thermowell			
Code	Nominal immersion of sensor L [mm]			
o L100	100			
o L160	160			
o L250	250			
o L400	400			
o L630	630			
L....	Other (please fill nominal immersion of sensor in mm)			
Code	Head			
o H1	Al alloy, cable outlet M20x1.5 for cable Ø 4 to 12.5 mm, IP 65			
o H2	Al alloy, cable outlet M20x1.5 for cable Ø 4 to 12.5 mm, IP 65			
o H3	Al alloy, with high cap for mounting of transmitter with Ø 44 mm, cable outlet M20x1.5 for cable Ø 4 to 12.5 mm, IP 65			
o H4N	Al alloy, with low cap, cable outlet M20x1.5 for cable Ø 4 to 12.5 mm, IP 65			
o H4	Al alloy, with high cap for mounting of transmitter with Ø 62 mm, cable outlet M20x1.5 for cable Ø 4 to 12.5 mm, IP 65			
o H5N	Al alloy, with low cap, ground clamps, cable outlet M20x1.5 for cable Ø 5 to 10 mm, IP 65			
o H5	Al alloy, with high cap for mounting of transmitter with Ø 62 mm, ground clamps, cable outlet M20x1.5 for cable Ø 5 to 10 mm, IP 65			
o H5PA	Polyamide, with high cap for mounting of transmitter with Ø 62 mm, Tmax 80 °C, cable outlet M20x1.5 for cable Ø 4 to 12.5 mm, IP 65			
o H6	Al alloy, ground clamps, thread for cable outlet M20x1.5, IP 68			
o H7	Stainless steel, ground clamps, thread for cable outlet M20x1.5, IP 68			
...D	Double cable outlet - only for codes H4, H4N, H5, H5N			
...W	Sensor head with peephole for display - only for codes H4 Z1, H4D Z1, H5 Z1E and S2, S3; not for double sensors			
H9	Other			
Code	Cold-end of measuring insert			
o S1	With ceramic terminal block (diameter 42 mm) on flange of measuring insert (only for diameter 6 mm (code D3))			
o S2	For single sensor, without terminal block, with set for mounting of transmitter on flange of measuring insert (instead of terminal block)			
o S3	For single sensor, with mounted selected transmitter on flange of measuring insert (necessary specifications of transmitter)			
o S4	For double sensor, without terminal block, with set for mounting of two transmitters (not suitable for H1, H2, H5N, H6 and H7)			
S9	Other			
Code	Measuring insert diameter [mm]			
o D1	Ø 3			
o D2	Ø 4.5 (only for TC)			
o D3	Ø 6			
D9	Other			
Code	Extension piece /Nominal length of extension piece N/	Max. temperature of connection thread		
o N145	With extension piece N=145 mm (standard)	500 °C		
N...	Other (please fill nominal length of extension piece in mm)			
Code	Process connection			
o P3	Male thread M20x1.5			
o P5	Male thread G1/2"			
o P7	Male thread 1/2"NPT			
P9	Other			

# Modular Resistance and Thermocouple Temperature Sensors without/with Transmitter ModuTEMP® 70

OPTIONAL ACCESSORIES	
	<b>Versions for explosive atmosphere of gasses or dusts</b>
◦ EI	(Ex) II 2G Ex ia IIC T6...Tx°C Gb (Ex) II 1/2D Ex ia IIIC T85°C...Tx°C Da/Db - only for version with heads codes H5, H5N, H6, H7
	<b>Indication units</b>
Z1	LED display mounted in sensor head (only for code H4(D)W and S2, S3; operating temperature -20 to +80 °C)
Z1E	Intrinsically safe LED display in sensor head (Ex) II 2G Ex ia IIC T6 (only for codes H5W and S2, S3; operating temperature -20 to +80 °C)
	<b>Cable outlet<sup>2)</sup></b>
• KM1	Cable outlet, nickel-plated brass, IP 68, M20x1.5, for cable Ø 5 to 10 mm (standard for H6, H7)
KM4	Cable outlet, stainless steel, IP 68, M20x1.5, for cable Ø 7 to 12 mm
• KME1	Cable outlet, nickel-plated brass, Ex d, M20x1.5, IP 68, for fixed assembly cable Ø 4.5 to 8.5 mm
• KME2	Cable outlet, nickel-plated brass, Ex d, M20x1.5, IP 68, for fixed assembly cable Ø 7 to 12 mm
KME3	Cable outlet, stainless steel, Ex d, M20x1.5, IP 68, for fixed assembly cable Ø 4 to 8 mm
KME5	Cable outlet, polyamide (light blue), Ex e, M20x1.5, IP 68, for fixed assembly cable Ø 5 to 9 mm, operating temperature -20 to +95 °C (not for H5PA)
KME6	Cable outlet, polyamide (light blue), Ex e, M20x1.5, IP 68, for fixed assembly cable Ø 6.5 to 12 mm, operating temperature -20 to +95 °C (not for H5PA)
KM9	Other
• PK1	Lock anti pull-up cable for Ex d cable outlet KME1
• PK2	Lock anti pull-up cable for Ex d cable outlet KME2
	<b>Snap lock</b>
• RU	Snap lock - only with codes H2, H4, H4N, H5, H5N
	<b>Calibration in customer defined points, including certificate of calibration</b>
◦ KTE31A	Resistance temperature sensor calibration in three points in range -40 to +660 °C
◦ KTE51A	Resistance temperature sensor calibration in five points in range -40 to +660 °C
◦ KTE32AA	Thermocouple temperature sensor calibration in three points in range -40 to +660 °C
◦ KTE52AA	Thermocouple temperature sensor calibration in five points in range -40 to +660 °C
◦ KTE32AB	Thermocouple temperature sensor calibration in three points in range -40 to +1100 °C
◦ KTE52AB	Thermocouple temperature sensor calibration in five points in range -40 to +1100 °C
◦ KTE32B	Thermocouple temperature sensor calibration in three points in range +400 to +1300 °C
◦ KTE52B	Thermocouple temperature sensor calibration in five points in range +400 to +1300 °C
KTE9	Other
	<b>Extended warranty</b>
◦ WE36	Product warranty 36 months - not for code VR
WE..	Other (the number of months must be added to the code) - not for code VR
	<b>Accessories</b>
• BZS	Stainless steel tag for attachment (70x15 mm) with laser description according to the order
• PPZ	Laser description of sensor according to the order
• Q1	Material certificate according to EN 10204, 3.1
	<b>Transmitters for headmounting</b>
• P5310 H10	Transmitter with LHP protocol (see data sheet No. 0824)
◦ P5310EN2 H10	Transmitter with LHP protocol, (Ex) II 3G Ex nA IIC T4 Gc (see data sheet No. 0824)
• P5311 H10	Transmitter with LHP protocol with galvanic isolation (see data sheet No. 0824)
◦ P5311EN2 H10	Transmitter with LHP protocol with galvanic isolation, (Ex) II 3G Ex nA IIC T4 Gc (see data sheet No. 0824)
◦ P5311E1 H10	Transmitter with LHP protocol with galvanic isolation, (Ex) II 1G Ex ia IIC T4-T6 Ga, (Ex) II 1D Ex ia IIIC T106°C Da (see data sheet No. 0824)
• P5315 H10	Precision transmitter with LHP protocol with galvanic isolation (see data sheet No. 2098)
P5315EN2 H10	Precision transmitter with LHP protocol with galvanic isolation, (Ex) II 3G Ex nA [ic] IIC T4 Gc (see data sheet No. 2098)
• P5320 H10	Precision transmitter with HART protocol with galvanic isolation (see data sheet No. 0825)
◦ P5320EN2 H10	Precision transmitter with HART protocol with galvanic isolation, (Ex) II 3G Ex nA [ic] IIC T4 Gc (see data sheet No. 0825)
P5320E1 H10	Precision transmitter with HART protocol with galvanic isolation, (Ex) II 1G Ex ia IIC T4-T6 Ga, (Ex) II 1D Ex ia IIIC Txx°C Da (see data sheet No. 0825)

**Example of order: T1070 04 F2 J43 L160 H3 S1 D3 N145 P3 KTE31A (-40, 200, 500 °C)**

• ... Ex stock version    ◦ ... Marked version can be dispatched up to 5 working days (with calibration up to two weeks)

<sup>1)</sup> ... Not allowable to use two-wire connection because of nickel inner wiring.

<sup>2)</sup> ... The heads H1, H2, H3, H4, H4N, H5, H5N are usually equipped with nickel-plated brass cable outlet for cable with diameter 4 to 12.5 mm.

**ModuTEMP® 70 - Sensors without fitting**

Table 4

Type	Description		
o T1070	Resistance temperature sensor without fitting		
o T1570	Thermocouple temperature sensor without fitting		
Code	Temperature sensor		
	<i>Resistance (RTD)</i>		
	<i>Sheath material</i>		
	<i>Max. temperature of use</i>		
o 04	1xPt100, two-wire inside wiring	1.4404	up to 500 °C
o 06	1xPt100, four-wire inside wiring	1.4404	up to 600 °C
06HT	1xPt100, four-wire inside wiring	Inconel 600	up to 700 °C - only for code F7
o 07	2xPt100, three-wire inside wiring	1.4404	up to 600 °C
08	2xPt100, two-wire inside wiring	1.4404	up to 500 °C
09	2xPt100, four-wire inside wiring	1.4404	up to 600 °C - only for codes S4 and S5
...VR	Increased resistance to vibration and shock		up to 500 °C - only for code 06 F2 ... S5
	<i>Thermocouple (TC)</i>	<i>Sheath material</i>	<i>Measuring range</i>
o 21	1x"J" (Fe-CuNi), insulated	1.4541	-200 to +800 °C
o 61	2x"J" (Fe-CuNi), insulated, isolated junctions	1.4541	-200 to +800 °C
o 22	1x"K" (NiCr-NiAl), insulated	Inconel 600	-200 to +1100 °C
o 62	2x"K" (NiCr-NiAl), insulated, isolated junctions	Inconel 600	-200 to +1100 °C
23	1x"N" (NiCrSi-NiSi), insulated	Inconel 600	-200 to +1100 °C
63	2x"N" (NiCrSi-NiSi), insulated, isolated junctions	Inconel 600	-200 to +1100 °C
22HT	1x"K" (NiCr-NiAl), insulated	Nicrobell/Pyrosil	-200 to +1300 °C
62HT	2x"K" (NiCr-NiAl), insulated, isolated junctions	Nicrobell/Pyrosil	-200 to +1300 °C
23HT	1x"N" (NiCrSi-NiSi), insulated	Nicrobell/Pyrosil	-200 to +1300 °C
63HT	2x"N" (NiCrSi-NiSi), insulated, isolated junctions	Nicrobell/Pyrosil	-200 to +1300 °C
...U	Grounded version of junction TC		
99	Other		
Code	Accuracy class	Inside wiring	Measuring range
	<i>Resistance (RTD) according to EN 60751</i>		
o F1	B	Cu	-50 to +300 °C - not for code 06HT
o F2	B	Cu	-70 to +500 °C - not for code 06HT
o F3	B	Ni <sup>1)</sup>	-200 to +600 °C - only for codes 06, 07 and 09
o F7	B	Ni <sup>1)</sup>	-200 to +700 °C - only for code 06HT
o F4	A	Cu	-30 to +300 °C - only for codes 06, 07 and 09
o F5	A	Cu	-100 to +450 °C - only for codes 06, 07 and 09
F9	Other		
	<i>Thermocouple (TC) according to EN 60584-1</i>		
o T7	2		
o T6	1		
T9	Other		
Code	Fitting of the sensor		
o B00	Without fitting		
o B01	Without fitting, with SST thermometer holder for wallmounting <sup>2)</sup>		
B99	Other without fitting		
Code	Nominal length L [mm]		
o L115	115		
o L175	175		
o L245	245		
o L305	305		
o L335	335		
o L395	395		
o L500	500		
o L545	545		
o L710	710		
o L775	775		
o L800	800		
o L1000	1000		
L1400	1400		
L2000	2000		
L....	Other (please fill nominal length in mm)		
Code	Head		
o H1	Al alloy, cable outlet M20x1.5 for cable Ø 4 to 12.5 mm, IP 65		
o H2	Al alloy, cable outlet M20x1.5 for cable Ø 4 to 12.5 mm, IP 65		
o H3	Al alloy, with high cap for mounting of transmitter with Ø 44 mm, cable outlet M20x1.5 for cable Ø 4 to 12.5 mm, IP 65		
o H4N	Al alloy, with low cap, cable outlet M20x1.5 for cable Ø 4 to 12.5 mm, IP 65		
o H4	Al alloy, with high cap for mounting of transmitter with Ø 62 mm, cable outlet M20x1.5 for cable Ø 4 to 12.5 mm, IP 65		
o H5N	Al alloy, with low cap, ground clamps, cable outlet M20x1.5 for cable Ø 5 to 10 mm, IP 65		
o H5	Al alloy, with high cap for mounting of transmitter with Ø 62 mm, ground clamps, cable outlet M20x1.5 for cable Ø 5 to 10 mm, IP 65		
o H5PA	Polyamide, with high cap for mounting of transmitter with Ø 62 mm, Tmax 80 °C, cable outlet M20x1.5 for cable Ø 4 to 12.5 mm, IP 65		
o H6	Al alloy, ground clamps, thread for cable outlet M20x1.5, IP 68		
o H7	Stainless steel, ground clamps, thread for cable outlet M20x1.5, IP 68		
...D	Double cable outlet - only for codes H4, H4N, H5, H5N		
...W	Sensor head with peephole for display - only for codes H4 Z1, H4D Z1, H5 Z1E and S2, S3; not for double sensors		
H9	Other		
Code	Cold-end of measuring insert		
o S1	With ceramic terminal block (diameter 42 mm) on flange of measuring insert (only for diameter 6 mm (code D3, D5))		
o S2	For single sensor, without terminal block, with set for mounting of transmitter on flange of measuring insert (instead of terminal block)		
o S3	For single sensor, with mounted selected transmitter on flange of measuring insert (necessary specifications of transmitter)		
o S4	For double sensor, without terminal block, with set for mounting of two transmitters (not suitable for H1, H2, H5N, H6 and H7)		
o S5	With ceramic terminal block (diameter 42 mm), embedded pins (according to NAMUR)		
S9	Other		
Code	Measuring insert diameter [mm]		
o D1	Ø 3		
o D2	Ø 4.5 (only for TC)		
o D3	Ø 6		
o D5	Ø 6 with distance sleeve Ø 8		
D9	Other		

OPTIONAL ACCESSORIES	
Versions for explosive atmosphere of gasses or dusts	
◦ EI	(Ex) II 1/2G Ex ia IIC T6...Tx°C Ga/Gb (Ex) II 1D Ex ia IIC T85°C...Tx°C Da - only for version with heads codes H5, H5N, H6, H7
Indication units	
Z1	LED display mounted in sensor head (only for code H4(D)W and S2, S3; operating temperature -20 to +80 °C)
Z1E	Intrinsically safe LED display in sensor head (Ex) II 2G Ex ia IIC T6 (only for codes H5W and S2, S3; operating temperature -20 to +80 °C)
Cable outlet <sup>3)</sup>	
• KM1	Cable outlet, nickel-plated brass, IP 68, M20x1.5, for cable Ø 5 to 10 mm (standard for H6, H7)
KM4	Cable outlet, stainless steel, IP 68, M20x1.5, for cable Ø 7 to 12 mm
• KME1	Cable outlet, nickel-plated brass, Ex d, M20x1.5, IP 68, for fixed assembly cable Ø 4.5 to 8.5 mm
• KME2	Cable outlet, nickel-plated brass, Ex d, M20x1.5, IP 68, for fixed assembly cable Ø 7 to 12 mm
KME3	Cable outlet, stainless steel, Ex d, M20x1.5, IP 68, for fixed assembly cable Ø 4 to 8 mm
KME5	Cable outlet, polyamide (light blue), Ex e, M20x1.5, IP 68, for fixed assembly cable Ø 5 to 9 mm, operating temperature -20 to +95 °C (not for H5PA)
KME6	Cable outlet, polyamide (light blue), Ex e, M20x1.5, IP 68, for fixed assembly cable Ø 6.5 to 12 mm, operating temperature -20 to +95 °C (not for H5PA)
KM9	Other
• PK1	Lock anti pull-up cable for Ex d cable outlet KME1
• PK2	Lock anti pull-up cable for Ex d cable outlet KME2
Holder, snap lock	
• DH1	Holder for wallmounting (optional only for code B00 with head H1, H2, H3)
• RU	Snap lock - only with codes H2, H4, H4N, H5, H5N
Calibration in customer defined points, including certificate of calibration	
◦ KTE31A	Resistance temperature sensor calibration in three points in range -40 to +660 °C
◦ KTE51A	Resistance temperature sensor calibration in five points in range -40 to +660 °C
◦ KTE32AA	Thermocouple temperature sensor calibration in three points in range -40 to +660 °C
◦ KTE52AA	Thermocouple temperature sensor calibration in five points in range -40 to +660 °C
◦ KTE32AB	Thermocouple temperature sensor calibration in three points in range -40 to +1100 °C
◦ KTE52AB	Thermocouple temperature sensor calibration in five points in range -40 to +1100 °C
◦ KTE32B	Thermocouple temperature sensor calibration in three points in range +400 to +1300 °C
◦ KTE52B	Thermocouple temperature sensor calibration in five points in range +400 to +1300 °C
KTE9	Other
Extended warranty	
◦ WE36	Product warranty 36 months - not for code VR
WE..	Other (the number of months must be added to the code) - not for code VR
Accessories	
• BZS	Stainless steel tag for attachment (70x15 mm) with laser description according to the order
• PPZ	Laser description of sensor according to the order
Fixing shift pipe unions	
• UPS3M12	Fixing shift pipe union for diameter 3 mm, connecting thread M12x1.5 (see data sheet No. 0126)
• UPS4,5M12	Fixing shift pipe union for diameter 4.5 mm, connecting thread M12x1.5 (see data sheet No. 0126)
• UPS6M20	Fixing shift pipe union for diameter 6 mm, connecting thread M20x1.5 (see data sheet No. 0126)
Transmitters for headmounting	
◦ P5310 H10	Transmitter with LHP protocol (see data sheet No. 0824)
◦ P5310EN2 H10	Transmitter with LHP protocol, (Ex) II 3G Ex nA IIC T4 Gc (see data sheet No. 0824)
• P5311 H10	Transmitter with LHP protocol with galvanic isolation (see data sheet No. 0824)
◦ P5311EN2 H10	Transmitter with LHP protocol with galvanic isolation, (Ex) II 3G Ex nA IIC T4 Gc (see data sheet No. 0824)
◦ P5311E1 H10	Transmitter with LHP protocol with galvanic isolation, (Ex) II 1G Ex ia IIC T4-T6 Ga, (Ex) II 1D Ex ia IIC T106°C Da (see data sheet No. 0824)
• P5315 H10	Precision transmitter with LHP protocol with galvanic isolation (see data sheet No. 2098)
P5315EN2 H10	Precision transmitter with LHP protocol with galvanic isolation, (Ex) II 3G Ex nA [ic] IIC T4 Gc (see data sheet No. 2098)
• P5320 H10	Precision transmitter with HART protocol with galvanic isolation (see data sheet No. 0825)
• P5320EN2 H10	Precision transmitter with HART protocol with galvanic isolation, (Ex) II 3G Ex nA [ic] IIC T4 Gc (see data sheet No. 0825)
P5320E1 H10	Precision transmitter with HART protocol with galvanic isolation, (Ex) II 1G Ex ia IIC T4-T6 Ga, (Ex) II 1D Ex ia IIC Txx°C Da (see data sheet No. 0825)
Example of order: T1070 04 F2 B00 L175 H3 S1 D3 KTE31A (-40, 200, 500 °C)	

Typ	Fixing shift pipe union for sheath temperature sensor		
Description			
• P	Fixing shift pipe union for sheath temperature sensor		
Code	Version	T <sub>MAX</sub>	P <sub>MAX</sub>
• S <sup>5)</sup>	With stainless steel cutting ring, pipe union of stainless steel material	600 °C / 0.1 MPa	4 MPa / 100 °C
• T <sup>6)</sup>	With PTFE sealing ring, pipe union of stainless steel material	200 °C / 0.1 MPa	0.6 MPa / 100 °C
Connection thread Z			
• M01	M8x1	- only for sensors with diameter sheath 3 mm	
• M02	M12x1.5	- only for sensors with diameter sheath 3 to 6 mm	
M03	M16x1.5	- only for sensors with diameter sheath 3 to 6 mm	
• M04	M20x1.5	- only for sensors with diameter sheath 3 to 6 mm	
• G01	G1/8"	- only for sensors with diameter sheath 3 mm	
• G02	G1/4"	- only for sensors with diameter sheath 3 to 6 mm	
• G03	G3/8"	- only for sensors with diameter sheath 3 to 6 mm	
• G04	G1/2"	- only for sensors with diameter sheath 3 to 6 mm	
N01	1/8" NPT	- only for sensors with diameter sheath 3 mm	
N02	1/4" NPT	- only for sensors with diameter sheath 3 to 6 mm	
N03	3/8" NPT	- only for sensors with diameter sheath 3 to 6 mm	
N04	1/2" NPT	- only for sensors with diameter sheath 3 to 6 mm	
Outer diameter of stem sensor			
• D30	3 mm		
D45	4,5 mm		
• D60	6 mm		
Example of order: PS M04 D30			

- 1) ... Ex stock version    ◦ ... Marked version can be dispatched up to 5 working days (with calibration up to two weeks)
- 2) ... Not allowable to use two-wire connection because of nickel inner wiring.
- 3) ... Standard for heads H4, H5.., H6 and H7; it is possible to use for heads H1, H2 and H3, but the version B00 with holder DH1 is cheaper.
- 4) ... The heads H1, H2, H3, H4, H4N, H5, H5N are usually equipped with nickel-plated brass cable outlet for cable with diameter 4 to 12.5 mm.
- 5) ... It is suitable only for non-flowing gas medium, free of mechanical stress including impacts and vibrations, where adjustable nominal length is required and it is impossible to use fixing pipe unions PT because of high temperature.
- 6) ... Adjustable nominal length only for first time of mounting.
- 6) ... Always adjustable nominal length.

## ModuTEMP® 70 - Straight sensors

Table 5

Type	Description		
○ T1070	Straight resistance temperature sensor		
○ T1570	Straight thermocouple temperature sensor		
Code	Temperature sensor		
	<i>Resistance (RTD)</i>	<i>Sheath material</i>	<i>Max. temperature of use</i>
○ 04	1xPt100, two-wire inside wiring	1.4404	up to 500 °C
○ 06	1xPt100, four-wire inside wiring	1.4404	up to 600 °C
06HT	1xPt100, four-wire inside wiring	Inconel 600	up to 700 °C - only for code F7
○ 07	2xPt100, three-wire inside wiring	1.4404	up to 600 °C
08	2xPt100, two-wire inside wiring	1.4404	up to 500 °C
09	2xPt100, four-wire inside wiring	1.4404	up to 600 °C - only for codes S4 and S5
...VR	Increased resistance to vibration and shock		up to 500 °C - only for code 06 F2 ... S5
	<i>Thermocouple (TC)</i>	<i>Sheath material</i>	<i>Measuring range</i>
○ 21	1x"J" (Fe-CuNi), insulated	1.4541	-200 to +800 °C
○ 61	2x"J" (Fe-CuNi), insulated, isolated junctions	1.4541	-200 to +800 °C
○ 22	1x"K" (NiCr-NiAl), insulated	Inconel 600	-200 to +1100 °C
○ 62	2x"K" (NiCr-NiAl), insulated, isolated junctions	Inconel 600	-200 to +1100 °C
23	1x"N" (NiCrSi-NiSi), insulated	Inconel 600	-200 to +1100 °C
63	2x"N" (NiCrSi-NiSi), insulated, isolated junctions	Inconel 600	-200 to +1100 °C
22HT	1x"K" (NiCr-NiAl), insulated	Nicrobell/Pyrosil	-200 to +1300 °C
62HT	2x"K" (NiCr-NiAl), insulated, isolated junctions	Nicrobell/Pyrosil	-200 to +1300 °C
23HT	1x"N" (NiCrSi-NiSi), insulated	Nicrobell/Pyrosil	-200 to +1300 °C
63HT	2x"N" (NiCrSi-NiSi), insulated, isolated junctions	Nicrobell/Pyrosil	-200 to +1300 °C
...U	Grounded version of junction TC		
99	Other		
Code	Accuracy class	Inside wiring material	Measuring range
	<i>Resistance (RTD) according to EN 60751</i>		
○ F1	B	Cu	-50 to +300 °C - not for code 06HT
○ F2	B	Cu	-70 to +500 °C - not for code 06HT
○ F3	B	Ni <sup>1)</sup>	-200 to +600 °C - only for codes 06, 07 and 09
○ F7	B	Ni <sup>1)</sup>	-200 to +700 °C - only for code 06HT
○ F4	A	Cu	-30 to +300 °C - only for codes 06, 07 and 09
○ F5	A	Cu	-100 to +450 °C - only for codes 06, 07 and 09
F9	Other		
	<i>Thermocouple (TC) according to EN 60584-1</i>		
○ T7	2		
○ T6	1		
T9	Other		
Code	Fitting of the sensor: straight sensor with protective tube	Fitting material	T <sub>MAX</sub>
○ B53	Ø 11 x 2 mm	1.4541	up to 800 °C
○ B63	Ø 14 x 2.5 mm	1.4541	up to 800 °C
○ B64	Ø 14 x 2.5 mm	1.4845	up to 1100 °C
○ B66	Ø 15 x 1.3 mm	Kanthal AF	up to 1300 °C - only for code ...HT, H4..., H5..
○ B73	Ø 20 x 3 mm	1.4541	up to 800 °C
○ B74	Ø 20 x 3 mm	1.4845	up to 1100 °C
○ B83	Ø 22 x 2 mm	1.4541	up to 800 °C
○ B84	Ø 22 x 2 mm	1.4845	up to 1100 °C
○ B85	Ø 22 x 2 mm	1.4762	up to 1100 °C
○ B86	Ø 22 x 1.3 mm	Kanthal AF	up to 1300 °C - only for code ...HT
... C	Inner ceramic protective tube Ø 15 mm of C610 (only for tubes 22x2 mm and 22x1.3 mm and heads HA, HAN, not for S8)		
○ B84Z	Ø 22 x 3.5	1.4845	up to 1100 °C
B842	Ø 22 x 7.5 mm in length 200 mm, then 22 x 2 mm	1.4845	up to 1100 °C
B843	Ø 22 x 7.5 mm in length 300 mm, then 22 x 2 mm	1.4845	up to 1100 °C
B852	Ø 22 x 7.5 mm in length 200 mm, then 22 x 2 mm	1.4762	up to 1100 °C
B853	Ø 22 x 7.5 mm in length 300 mm, then 22 x 2 mm	1.4762	up to 1100 °C
B99	Other straight		
Code	Nominal length L [mm]		
○ L180	180		
○ L250	250		
○ L310	310		
○ L400	400		
○ L500	500		
○ L600	600		
○ L710	710		
○ L800	800		
○ L1000	1000		
L1200	1200		
L1400	1400		
L1600	1600		
L2000	2000		
L ....	Other (please fill nominal length in mm)		
Code	Head		
○ H1	Al alloy, cable outlet M20x1.5 for cable Ø 4 to 12.5 mm, IP 65		
○ H2	Al alloy, cable outlet M20x1.5 for cable Ø 4 to 12.5 mm, IP 65		
○ H3	Al alloy, with high cap for mounting of transmitter with Ø 44 mm, cable outlet M20x1.5 for cable Ø 4 to 12.5 mm, IP 65		
○ H4N	Al alloy, with low cap, cable outlet M20x1.5 for cable Ø 4 to 12.5 mm, IP 65		
○ H4	Al alloy, with high cap for mounting of transmitter with Ø 62 mm, cable outlet M20x1.5 for cable Ø 4 to 12.5 mm, IP 65		
○ H5N	Al alloy, with low cap, ground clamps, cable outlet M20x1.5 for cable Ø 5 to 10 mm, IP 65		
○ H5	Al alloy, with high cap for mounting of transmitter with Ø 62 mm, ground clamps, cable outlet M20x1.5 for cable Ø 5 to 10 mm, IP 65		
○ H5PA	Polyamide, with high cap for mounting of transmitter with Ø 62 mm, Tmax 80 °C, cable outlet M20x1.5 for cable Ø 4 to 12.5 mm, IP 65		
○ H6	Al alloy, ground clamps, thread for cable outlet M20x1.5, IP 68		
○ H7	Stainless steel, ground clamps, thread for cable outlet M20x1.5, IP 68		
○ HAN	type A, Al alloy, with low cap, cable outlet M20x1.5, IP 53 - only for B8x		
○ HA	type A, Al alloy, with high cap for mounting of transmitter with Ø 62 mm, cable outlet M20x1.5, IP 53 - only for B8x		
...D	Double cable outlet - only for codes H4, H4N, H5, H5N, HA, HAN		
...W	Sensor head with peephole for display - only for codes H4 Z1, H4D Z1, H5 Z1E and S2, S3; not for double sensors		
H9	Other		

# Modular Resistance and Thermocouple Temperature Sensors without/with Transmitter ModuTEMP® 70

Code	Cold-end of measuring insert	
○ S1	With ceramic terminal block (diameter 42 mm) on flange of measuring insert	
○ S2	For single sensor, without terminal block, with set for mounting of transmitter on flange of measuring insert (instead of terminal block)	
○ S3	For single sensor, with mounted selected transmitter on flange of measuring insert (necessary specifications of transmitter)	
○ S4	For double sensor, without terminal block, with set for mounting of two transmitters (not suitable for H1, H2, H5N, H6 and H7)	
○ S5	With ceramic terminal block (diameter 42 mm), embedded pins (according to NAMUR)	
S8	With ceramic terminal block (diameter 55 mm), with hole for insertion of control sensor - only for HA, HAN	
S9	Other	
Code	OPTIONAL ACCESSORIES	
Code	Versions for explosive atmosphere of gasses or dusts	
	Flameproof enclosure "Ex d" only for gasses and protection by enclosure "Ex i" only for dusts, intrinsically safe version "Ex i" for gasses and dusts	
○ ED/ET	(Ex) II 1/2G Ex da/db IIC T6...Tx°C Ga/Gb - only for version with heads codes H6, H7 (Ex) II 1/2D Ex ta/tb IIIC T90°C...Tx°C Da/Db	
○ EI	(Ex) II 1/2G Ex ia IIC T6...Tx°C Ga/Gb - only for version with heads codes H5, H5N, H6, H7 (Ex) II 1D Ex ia IIIC T85°C...Tx°C Da	
Code	Protective spray	T <sub>MAX</sub> (with spray)
X01	Polyamide PA 11	100 °C (depends on measured medium)
X02	E-CTFE "Halar"	170 °C (depends on measured medium)
X03	PFA	260 °C (depends on measured medium)
X04	ETFE "Hyflon"	130 °C (depends on measured medium)
X05	PTFE	260 °C (depends on measured medium)
X07	Hard metal coating (Fe-Cr-Mn-Si-B-C) for abrasive medium	925 °C
X08	Corundum spray for intense abrasive medium	according to specific composition of coating
X99	Other	
Code	Indication units	
Z1	LED display mounted in sensor head (only for code H4(D)W and S2, S3; operating temperature -20 to +80 °C)	
Z1E	Intrinsically safe LED display in sensor head (Ex) II 2G Ex ia IIC T6 (only for codes H5W and S2, S3; operating temperature -20 to +80 °C)	
Code	Cable outlet <sup>2)</sup>	
• KM1	Cable outlet, nickel-plated brass, IP 68, M20x1.5, for cable Ø 5 to 10 mm (standard for H6, H7)	
KM4	Cable outlet, stainless steel, IP 68, M20x1.5, for cable Ø 7 to 12 mm	
• KME1	Cable outlet, nickel-plated brass, Ex d, M20x1.5, IP 68, for fixed assembly cable Ø 4.5 to 8.5 mm	
• KME2	Cable outlet, nickel-plated brass, Ex d, M20x1.5, IP 68, for fixed assembly cable Ø 7 to 12 mm	
KME3	Cable outlet, stainless steel, Ex d, M20x1.5, IP 68, for fixed assembly cable Ø 4 to 8 mm	
KME5	Cable outlet, polyamide (light blue), Ex e, M20x1.5, IP 68, for fixed assembly cable Ø 5 to 9 mm, operating temperature -20 to +95 °C (not for H5PA)	
KME6	Cable outlet, polyamide (light blue), Ex e, M20x1.5, IP 68, for fixed assembly cable Ø 6.5 to 12 mm, operating temperature -20 to +95 °C (not for H5PA)	
KM9	Other	
• PK1	Lock anti pull-up cable for Ex d cable outlet KME1	
• PK2	Lock anti pull-up cable for Ex d cable outlet KME2	
Code	Snap lock	
• RU	Snap lock - only for codes H2, H4, H4N, H5, H5N, HA, HAN	
Code	Calibration in customer defined points, including certificate of calibration	
○ KTE31A	Resistance temperature sensor calibration in three points in range -40 to +660 °C	
○ KTE51A	Resistance temperature sensor calibration in five points in range -40 to +660 °C	
○ KTE32AB	Thermocouple temperature sensor calibration in three points in range -40 to +1100 °C	
○ KTE52AB	Thermocouple temperature sensor calibration in five points in range -40 to +1100 °C	
○ KTE32B	Thermocouple temperature sensor calibration in three points in range +400 to +1300 °C	
○ KTE52B	Thermocouple temperature sensor calibration in five points in range +400 to +1300 °C	
KTE9	Other	
Code	Extended warranty	
○ WE36	Product warranty 36 months - not for code VR	
WE..	Other (the number of months must be added to the code) - not for code VR	
Code	Accessories	
• BZS	Stainless steel tag for attachment (70x15 mm) with laser description according to the order	
• PPZ	Laser description of sensor according to the order	
• Q1	Material certificate according to EN 10204, 3.1	
Code <sup>3)</sup>	Fixing shift pipe unions and flanges	
• UPS11M20	Fixing shift pipe union for diameter 11 mm, connecting thread M20x1.5 (see data sheet No. 0126)	
• UPS14M27	Fixing shift pipe union for diameter 14 mm, connecting thread M27x2 (see data sheet No. 0126)	
• UPS15M27	Fixing shift pipe union for diameter 15 mm, connecting thread M27x2 (see data sheet No. 0126)	
• UPS20M30	Fixing shift pipe union for diameter 20 mm, connecting thread M30x2 (see data sheet No. 0126)	
• UPS22M33	Fixing shift pipe union for diameter 22 mm, connecting thread M33x2 (see data sheet No. 0126)	
• UP01	Fixing shift flange for diameter 14 mm (see data sheet No. 0126)	
• UP02	Fixing shift flange for diameter 15 mm (see data sheet No. 0126)	
• UP03	Fixing shift flange for diameter 22 mm (see data sheet No. 0126)	
P9	Other	
Code	Transmitters for headmounting	
• P5310 H10	Transmitter with LHP protocol (see data sheet No. 0824)	
○ P5310EN2 H10	Transmitter with LHP protocol, (Ex) II 3G Ex nA IIC T4 Gc (see data sheet No. 0824)	
• P5311 H10	Transmitter with LHP protocol with galvanic isolation (see data sheet No. 0824)	
○ P5311EN2 H10	Transmitter with LHP protocol with galvanic isolation, (Ex) II 3G Ex nA IIC T4 Gc (see data sheet No. 0824)	
○ P5311E1 H10	Transmitter with LHP protocol with galvanic isolation, (Ex) II 1G Ex ia IIC T4-T6 Ga, (Ex) II 1D Ex ia IIIC T106°C Da (see data sheet No. 0824)	
• P5315 H10	Precision transmitter with LHP protocol with galvanic isolation (see data sheet No. 2098)	
P5315EN2 H10	Precision transmitter with LHP protocol with galvanic isolation, (Ex) II 3G Ex nA [ic] IIC T4 Gc (see data sheet No. 2098)	
• P5320 H10	Precision transmitter with HART protocol with galvanic isolation (see data sheet No. 0825)	
○ P5320EN2 H10	Precision transmitter with HART protocol with galvanic isolation, (Ex) II 3G Ex nA [ic] IIC T4 Gc (see data sheet No. 0825)	
P5320E1 H10	Precision transmitter with HART protocol with galvanic isolation, (Ex) II 1G Ex ia IIC T4-T6 Ga, (Ex) II 1D Ex ia IIIC Txx°C Da (see data sheet No. 0825)	
Example of order: T1070 04 F2 B53 L310 H3 S1 KTE31A (-40, 200, 500 °C)		

• ... Ex stock version    ° ... Marked version can be dispatched up to 5 working days (with calibration up to two weeks)

<sup>1)</sup> ... Not allowable to use two-wire connection because of nickel inner wiring.

<sup>2)</sup> ... The heads H1, H2, H3, H4, H4N, H5, H5N are usually equipped with nickel-plated brass cable outlet for cable with diameter 4 to 12.5 mm.

<sup>3)</sup> ... It is suitable only for non-flowing gas medium, free of mechanical stress including impacts and vibrations, where adjustable nominal length is required and it is impossible to use fixing pipe unions PT because of high temperature.

# ModuTEMP® 70 - Spatial sensors for explosive atmosphere of gasses or dusts

Table 6

Type	Description
o T1070	Spatial resistance temperature sensor for explosive atmosphere
Code	Temperature sensor
	Resistance (RTD) Sheath material
o 04	1xPt100, two-wire inside wiring 1.4404
o 06 <sup>1)</sup>	1xPt100, four-wire inside wiring 1.4404
o 07 <sup>1)</sup>	2xPt100, three-wire inside wiring 1.4404
o 08	2xPt100, two-wire inside wiring 1.4404
99	Other
Code	Accuracy class Inside wiring material Measuring range
	Resistance (RTD) according to EN 60751
o F1	B Cu -50 to +100 °C (85 °C for code ED)
o F4	A Cu -30 to +100 °C (85 °C for code ED)
F9	Other
Code	Fitting of the sensor
o P1E	Spatial for explosive atmosphere
Code	Nominal length L [mm]
o L75	75
Code	Head
o H5N	Al alloy, with low cap, ground clamps, cable outlet M20x1.5 for cable Ø 5 to 10 mm, IP 65
o H5	Al alloy, with high cap for mounting of transmitter with Ø 62 mm, ground clamps, cable outlet M20x1.5 for cable Ø 5 to 10 mm, IP 65
o H6	Al alloy, ground clamps, thread for cable outlet M20x1.5, IP 68
o H7	Stainless steel, ground clamps, thread for cable outlet M20x1.5, IP 68
...D	Double cable outlet - only for codes H5, H5N
...W	Sensor head with peephole for display - only for codes H5 Z1E and S2, S3; not for double sensors
H9	Other
Code	Cold-end of measuring insert
o S1	With ceramic terminal block (diameter 42 mm) on flange of measuring insert
o S2	For single sensor, without terminal block, with set for mounting of transmitter on flange of measuring insert (instead of terminal block)
o S3	For single sensor, with mounted selected transmitter on flange of measuring insert (necessary specifications of transmitter)
o S4	For double sensor, without terminal block, with set for mounting of two transmitters (not suitable for H5N, H6 and H7)
o S5	With ceramic terminal block (diameter 42 mm), embedded pins (according to NAMUR)
S9	Other
Code	Measuring insert diameter [mm]
D1	Ø 3
o D3	Ø 6 (standard)
Code	Versions for explosive atmosphere of gasses or dusts
	Flameproof enclosure "Ex d" only for gasses and protection by enclosure "Ex i" only for dusts, intrinsically safe version "Ex i" for gasses and dusts
o ED/ET	(Ex) II 2G Ex db IIC T5/T6 Gb - only for version with heads codes H6, H7 (Ex) II 2D Ex tb IIIC T90°C Db
o EI	(Ex) II 2G Ex ia IIC T6...Tx°C Gb (Ex) II 1D Ex ia IIIC T85°C...Tx°C Da
Code	OPTIONAL ACCESSORIES
	Indication units
Z1E	Intrinsically safe LED display in sensor head (Ex) II 2G Ex ia IIC T6 (only for codes H5W and S2, S3; operating temperature -20 to +80 °C)
Code	Cable outlet <sup>2)</sup>
• KME1	Cable outlet, nickel-plated brass, Ex d, M20x1.5, IP 68, for fixed assembly cable Ø 4.5 to 8.5 mm
• KME2	Cable outlet, nickel-plated brass, Ex d, M20x1.5, IP 68, for fixed assembly cable Ø 7 to 12 mm
KME3	Cable outlet, stainless steel, Ex d, M20x1.5, IP 68, for fixed assembly cable Ø 4 to 8 mm
KME5	Cable outlet, polyamide (light blue), Ex e, M20x1.5, IP 68, for fixed assembly cable Ø 5 to 9 mm, operating temperature -20 to +95 °C (not for ED)
KME6	Cable outlet, polyamide (light blue), Ex e, M20x1.5, IP 68, for fixed assembly cable Ø 6.5 to 12 mm, operating temperature -20 to +95 °C (not for ED)
KM9	Other
• PK1	Lock anti pull-up cable for Ex d cable outlet KME1
• PK2	Lock anti pull-up cable for Ex d cable outlet KME2
Code	Snap lock
• RU	Snap lock - only with codes H5, H5N
Code	Calibration in customer defined points, including certificate of calibration
o KTE31A	Resistance temperature sensor calibration in three points in range -20 to +100 °C
o KTE41A	Resistance temperature sensor calibration in four points in range -20 to +100 °C
o KTE51A	Resistance temperature sensor calibration in five points in range -20 to +100 °C
KTE9	Other
Code	Accessories
• BZS	Stainless steel tag for attachment (70x15 mm) with laser description according to the order
• PPZ	Laser description of sensor according to the order
Code	Transmitters for headmounting
• P5310 H10	Transmitter with LHP protocol (see data sheet No. 0824)
o P5310EN2 H10	Transmitter with LHP protocol, (Ex) II 3G Ex nA IIC T4 Gc (see data sheet No. 0824)
• P5311 H10	Transmitter with LHP protocol with galvanic isolation (see data sheet No. 0824)
o P5311EN2 H10	Transmitter with LHP protocol with galvanic isolation, (Ex) II 3G Ex nA IIC T4 Gc (see data sheet No. 0824)
o P5311E1 H10	Transmitter with LHP protocol with galvanic isolation, (Ex) II 1G Ex ia IIC T4-T6 Ga, (Ex) II 1D Ex ia IIIC T106°C Da (see data sheet No. 0824)
• P5315 H10	Precision transmitter with LHP protocol with galvanic isolation (see data sheet No. 2098)
P5315EN2 H10	Precision transmitter with LHP protocol with galvanic isolation, (Ex) II 3G Ex nA [ic] IIC T4 Gc (see data sheet No. 2098)
• P5320 H10	Precision transmitter with HART protocol with galvanic isolation (see data sheet No. 0825)
• P5320EN2 H10	Precision transmitter with HART protocol with galvanic isolation, (Ex) II 3G Ex nA [ic] IIC T4 Gc (see data sheet No. 0825)
P5320E1 H10	Precision transmitter with HART protocol with galvanic isolation, (Ex) II 1G Ex ia IIC T4-T6 Ga, (Ex) II 1D Ex ia IIIC Txx°C Da (see data sheet No. 0825)
Example of order: T1070 04 F2 P1E L75 H5 S1 D3 KTE31A (-40, 50, 100 °C)	

• ... Ex stock version ° ... Marked version can be dispatched up to 5 working days (with calibration up to two weeks)

<sup>1)</sup> ... Not allowable to use two-wire connection because of nickel inner wiring.

<sup>2)</sup> ... The heads H5, H5N are usually equipped with nickel-plated brass cable outlet for cable with diameter 4 to 12.5 mm.